

1975 TOOLBAR Operator's Manual

Part #125-087-01-EN-OM



Intentionally Left Blank Page

Table of Contents

Introduction

| | |
|------------------------------|-----|
| To the Dealer | 1-2 |
| Delivery | 1-2 |
| Product Description | 1-3 |
| Purpose of This Manual | 1-3 |
| Warranty | 1-4 |

Safety Information

| | |
|--|------|
| Farm Safety | 2-2 |
| How You Can Improve Farm Safety | 2-2 |
| High Risk Factors on Farms | 2-2 |
| The Benefits of Improved Safety and Health Practices | 2-2 |
| Health and Safety Hazards on Farms | 2-3 |
| Safety Alert Symbol | 2-4 |
| Be Aware of Signal Words | 2-4 |
| Shutdown and Storage | 2-4 |
| For Your Protection | 2-4 |
| Equipment Safety Guidelines | 2-5 |
| Safe Transport | 2-5 |
| Safe Operation | 2-5 |
| Warning and Safety Lights | 2-6 |
| Rear View of Toolbar | 2-6 |
| Slow Moving Vehicle (SMV) | 2-7 |
| No Riders | 2-8 |
| Practice Safe Maintenance | 2-8 |
| Prepare for Emergencies | 2-9 |
| Anhydrous Ammonia (NH ₃) and Liquid Fertilizer | 2-9 |
| Safety Never Hurts | 2-9 |
| Orthman Serial Number Plate | 2-9 |
| Safety Decals | 2-10 |
| Orthman Center Decals | 2-10 |
| Orthman Wing Decals | 2-11 |

Major Components

| | |
|---|-----|
| Center | 3-2 |
| Wing | 3-3 |
| Lift Wheel | 3-4 |
| Lift Track | 3-5 |
| Tongue and Hitch | 3-6 |
| Central Commodity System (CCS) Planter Tongue and Hitch | 3-7 |

Preparation and Setup

| | |
|--|------|
| Preparing the Toolbar | 4-2 |
| Implement-to-Tractor Connection | 4-3 |
| Disconnecting Implement From Tractor | 4-4 |
| Outer Wing Fold | 4-5 |
| Outer Wing Latch | 4-6 |
| Gullwing Kit | 4-7 |
| Plumbing the Gullwing Kit | 4-7 |
| Leveling the Midwings | 4-8 |
| Fold Control Manifold | 4-10 |
| Manifold Connections | 4-10 |
| Front Side of Manifold | 4-10 |
| Right Side of Manifold | 4-11 |
| Left Side of Manifold | 4-11 |
| Adjusting the Fold Control Manifold | 4-12 |
| Adjust the Counterbalance Valves | 4-12 |
| Adjust the Sequence Valves | 4-13 |
| Implement Guidance | 4-14 |

Operation and Field Settings

| | |
|---|-----|
| Gullwing Feature and Toolbar Float | 5-2 |
| Float and Gullwing Linkage Component Identification | 5-2 |
| Gullwing Hydraulics | 5-3 |
| Hydraulic Bulkhead Connections | 5-4 |
| Toolbar Flex | 5-5 |
| Gullwing Up/Gullwing Down Force Contour | 5-6 |
| Toolbar Height and Orientation | 5-7 |
| Raised Position | 5-7 |
| Field Position | 5-8 |

Troubleshooting

| | |
|--|-----|
| Machine Frame | 6-2 |
| Preventative Measures | 6-2 |
| Troubleshooting | 6-3 |
| Components Showing Premature Wear | 6-3 |
| Toolbar Does Not Operate at the Proper Height | 6-3 |
| Toolbar Does Not Operate Level With the Ground | 6-3 |
| Toolbar Does Not Fold Correctly | 6-3 |
| Toolbar Wings Are Not Level or Straight | 6-3 |
| Hydraulic | 6-4 |
| Preventative Measures | 6-4 |
| Troubleshooting | 6-5 |
| Toolbar Wings Not Stacking Properly | 6-5 |
| Toolbar Outer Wings Not Folding In Before Stacking | 6-5 |
| Toolbar Outer Wings Fold Inward on Their Own During Field Operation | 6-5 |
| Machine Settles to the Ground on Its Own in Parked Position | 6-5 |
| Wings Not Gulling Down When Machine is Lowered | 6-6 |
| Gullwing Down Force is Not Enough to Keep Row Units in the Ground | 6-6 |
| Wings Gull Up When Machine is Placed in Field Position | 6-6 |
| Machine Lowers the Lifting Gauge Wheels Before the Hitch or Raises After the Hitch | 6-6 |
| Toolbar Wings Unstack Too Quickly | 6-6 |

Maintenance

| | |
|-----------------------------------|-----|
| Practice Safe Maintenance | 7-2 |
| Torque Specifications | 7-2 |
| Lubrication | 7-3 |
| Hitch Grease Locations | 7-3 |
| Lift Wheel/Track Grease Locations | 7-3 |
| Outer Wing Grease Locations | 7-4 |
| Midwing Grease Locations | 7-4 |
| Center Grease Locations | 7-4 |
| Implement Inspection | 7-5 |
| Implement Storage | 7-5 |
| Notes | 7-6 |

Page Intentionally Blank

Chapter 1

Introduction

| | |
|------------------------------|-----|
| To the Dealer | 1-2 |
| Delivery | 1-2 |
| Product Description | 1-3 |
| Purpose of This Manual | 1-3 |
| Warranty | 1-4 |

To the Dealer

This instruction contains important information for unloading of custom integral planters. Read instructions carefully before attempting to unload. While the custom integral planter is considered a factory assembled product, some components may have been removed from the machine to prevent damage during shipping, or to allow for consolidated shipments. Make sure all components are properly installed.

Inspect the implement thoroughly after assembly to be certain it is functioning properly before delivering it to the customer. The following checklist is a reminder of points to cover. Check off each item as it is found satisfactory or after proper adjustment is made.

| Pre-Delivery Checklist | |
|------------------------|--|
| | All hardware is properly tightened. |
| | Lubrication of grease fittings has been completed. |
| | All decals are properly located and readable. |
| | All implement tools and options are installed and set. |
| | Check overall condition of implement. |
| | Make sure operator's manual is included. |
| | |
| Date set up: | |
| Signature: | |

Delivery

At the time the machine is delivered, the following checklist is a reminder of information which should be conveyed directly to the customer. Check off each item as it is fully explained to customer.

| Delivery Checklist | |
|--------------------|--|
| | Introduce the machine to the customer. Give the customer the operator's manual and encourage them to read it. |
| | Make the customer aware of all the safety precautions that must be exercised when using and transporting the machine. |
| | Make customer aware of the different tooling options available. |
| | The machine does not come set to run in the field from the factory. See Chapter 5, "Operation and Field Settings" to help set the machine for optimal performance. Explain all operating adjustments. |
| | Explain to the customer that the life expectancy of this machine depends on regular maintenance as directed in the operator's manual. |
| | Tell the customer to use the proper tools for service and inform them of Orthman parts availability. |
| | Review recommended procedures for attaching and detaching planter from tractor. |
| | Inform the customer of safety precautions that must be observed when transporting. |
| | When the machine is transported on a road or highway at night or during the day, accessory lights and devices should be used for adequate warning to operators of other vehicles. In this regard, tell customer to check local governmental regulations. |
| | Write machine model number and serial number in the spaces provided below. |
| | To the best of my knowledge, this machine has been delivered ready for field use and the customer has been fully informed as to proper operation and care. |
| | |
| Date delivered: | Model number: |
| Signature: | Serial number: |

NOTE: After signing, copy this page. Keep signed delivery checklist in machine file at the dealership.

Product Description

Take advantage of wide-working widths without sacrificing all of the benefits of compact, mounted machines. The Orthman 1975 Toolbar combines rear-lift wheels/Soucy-tracks system with a semi-mount knuckle hitch in order to create the most maneuverable large stacking toolbar in the industry. The placement of the toolbar lift wheels/tracks significantly reduces the tractor hitch load and minimizes machine length. The pivoting knuckle hitch allows the toolbar a large range of motion while crossing field terrain or moving around the yard. The front-fold and stack wing design reduces the 1975 Toolbar to a compact transport configuration. When in the field position, the toolbar flexes in five sections with the mid and outer wings able to flex $\pm 8^\circ$ individually allowing 16° of total flex on each wing. The Wing Down Force System eliminates the use of weights allowing the hydraulic cylinders to apply down force evenly through the mid and outer wing. The toolbar can be utilized with the GPS Ready Tracker® IV or GPS Ready Shadow Tracker® Implement Guidance Systems in the wheeled version only, not available with tracks.

Purpose of This Manual

This manual is considered to be an integral component of the 1975 Toolbar and is designed to educate the owner and operators regarding safety, operation, maintenance, troubleshooting, and component identification.

All personnel involved in the operation of the 1975 Toolbar are responsible for reading and understanding the entire contents of this manual. This manual is designed to keep the operator safe and knowledgeable as well as prolong the life of the product, minimize downtime, and maximize field efficiency. This manual should accompany the product if it is ever sold.

We would like to thank you for placing your confidence in Orthman Mfg., Inc. Your 1975 Toolbar is manufactured to meet the highest standards and is built with Orthman precision and strength to increase your agricultural operation's dependability and profitability.

Warranty

Orthman Manufacturing, Inc. ("OMI") warrants each new whole good product to be free from defects in manufactured components and workmanship. This warranty is applicable only for the normal service life expectancy of the product or components, not to exceed twenty-four (24) consecutive months from date of purchase of the new OMI product to the original purchaser.

Purchased components installed by OMI (blades, bearings, controls, hoses, wheels, coulters, cylinders, fittings, points, etc.) shall be warranted by their respective manufacturer for a period of twelve (12) consecutive months from date of purchase of the new OMI product to the original purchaser.

A completed online Warranty Registration for the original purchaser must have been received by OMI to activate warranty coverage. Non receipt of warranty registration may void OMI warranty coverage. OMI warranty is non-transferable.

Genuine OMI replacement parts and components will be warranted for ninety (90) days from date of purchase or the remainder of the original equipment warranty period; whichever is greater.

All warranty work is to be performed by an authorized OMI dealer at the repairing dealer's location unless otherwise approved by Orthman Manufacturing, Inc. – Lexington, Nebraska.

Under no circumstances shall warranty cover any merchandise or component thereof, which, in the opinion of OMI, has been subjected to misuse, unauthorized modifications or alteration, accident, collision with obstruction/ground, or if repairs have been made with parts other than those approved by OMI. If the seal on the cylinder is broke (cylinder opened), it will void all warranty for cylinder.

OMI warranty policies do not cover travel expenses, after hours field/service time, overnight expenses, or expenses not related to that of regular shop labor rates or parts replaced during actual warranty repair. OMI reserves the right to adjust warranty labor credits so as not to exceed believed normal repair times as directed by warranty governing laws.

OMI obligation under this warranty shall be limited to repairing or replacing, free of charge to the purchaser, any part, in our judgment, showing evidence of such defect, provided further that such part shall be returned within thirty (30) days from the date of repair to OMI through the dealer or distributor from whom the product was purchased or repaired; transportation charges prepaid.

This warranty shall not be interpreted to render OMI liable for injury or damages of any kind or nature to person or property. This warranty does not extend to the loss of crops, loss of delay in harvesting/planting, or any expense or loss incurred for labor, substitute machinery, rental, or any subsequent reasons thereof.

Except as set forth above, OMI shall have no obligation or liability of any kind on account of its equipment and shall not be liable for special or consequential damages. OMI makes no other warranty, expressed or implied, and, specifically, OMI disclaims any implied warranty or merchantability or fitness for a particular purpose. Some sates or provinces do not permit limitations or exclusions of implied warranties or incidental or consequential damages, so the limitations or exclusion in this warranty may not apply.

This warranty is subject to any existing conditions of supply, which may directly affect OMI ability to obtain materials or manufacture replacement parts.

OMI reserves the right to make improvements in design or changes in specifications at any time, without incurring any obligation to owners of units previously sold.

No one person is authorized to alter, modify or enlarge this warranty nor the exclusions, limitations and reservations. For more information, please visit OMI website www.orthman.com.

Information subject to change without notice.

Provided warranty policy information supersedes all previous warranty considerations.

Orthman Manufacturing, Inc. – Lexington, NE

Rev. Date - 8/1/2021

Chapter 2

Safety Information

| | |
|--|------|
| Farm Safety | 2-2 |
| How You Can Improve Farm Safety | 2-2 |
| High Risk Factors on Farms | 2-2 |
| The Benefits of Improved Safety and Health Practices | 2-2 |
| Health and Safety Hazards on Farms | 2-3 |
| Safety Alert Symbol | 2-4 |
| Be Aware of Signal Words | 2-4 |
| Shutdown and Storage | 2-4 |
| For Your Protection | 2-4 |
| Equipment Safety Guidelines | 2-5 |
| Safe Transport | 2-5 |
| Safe Operation | 2-5 |
| Warning and Safety Lights | 2-6 |
| Rear View of Toolbar | 2-6 |
| Slow Moving Vehicle (SMV) | 2-7 |
| No Riders | 2-8 |
| Practice Safe Maintenance | 2-8 |
| Prepare for Emergencies | 2-9 |
| Anhydrous Ammonia (NH ₃) and Liquid Fertilizer | 2-9 |
| Safety Never Hurts | 2-9 |
| Orthman Serial Number Plate | 2-9 |
| Safety Decals | 2-10 |
| Orthman Center Decals | 2-10 |
| Orthman Wing Decals | 2-11 |

Farm Safety

Contrary to the popular image of fresh air and peaceful surroundings, a farm is not a hazard-free work setting. Every year, thousands of farm workers are injured and hundreds more die in farming accidents. According to the National Safety Council, agriculture is the most hazardous industry in the nation.

How You Can Improve Farm Safety

You can start by increasing your awareness of farming hazards and making a conscious effort to prepare for emergency situations including fires, vehicle accidents, electrical shocks from equipment and wires, and chemical exposures. Be especially alert to hazards that may affect children and the elderly. Minimize hazards by carefully selecting the products you buy to ensure that you provide good tools and equipment. Always use seat belts when operating tractors, and establish and maintain good housekeeping practices. Here are some other steps you can take to reduce illnesses and injuries on the farm:

- Read and follow instructions in equipment operator's manuals and on product labels.
- Inspect equipment routinely for problems that may cause accidents.
- Discuss safety hazards and emergency procedures with your workers.
- Install approved rollover protective structures, protective enclosures, or protective frames on tractors.
- Make sure that guards on farm equipment are replaced after maintenance.
- Review and follow instructions in material safety data sheets (MSDSs) and on labels that come with chemical products and communicate information on these hazards to your workers.

High Risk Factors on Farms

The following factors may increase risk of injury or illness for farm workers:

- Age — Injury rates are highest among children age 15 and under and adults over 65.
- Equipment and Machinery — Most farm accidents and fatalities involve machinery. Proper machine guarding and performing equipment maintenance according to manufacturers' recommendations can help prevent accidents.
- Protective Equipment — Using protective equipment such as seat belts on tractors and personal protective equipment (PPE) (safety gloves, coveralls, boots, hats, aprons, goggles, and face shields) could significantly reduce farming injuries.
- Take precautions to prevent entrapment and suffocation caused by unstable surfaces of grain storage bins, silos, or hoppers. Never "walk the grain."
- Be aware that methane gas, carbon dioxide, ammonia, and hydrogen sulfide can form in unventilated grain silos and manure pits and can suffocate or poison workers or explode.
- Take advantage of safety equipment, such as bypass starter covers, power take-off master shields, and slow-moving vehicle emblems.
- Medical Care — Hospitals and emergency medical care are typically not readily accessible in rural areas near farms.

The Benefits of Improved Safety and Health Practices

Orthman Manufacturing provides this document in the hope that everyone that has a job to do, does it SAFELY. Our goal and yours should be to end each day in the best possible health. Better safety and health practices reduce fatalities, injuries, and illnesses as well as associated costs such as workers' compensation insurance premiums, lost production, and medical expenses. A safer and more healthful workplace improves morale and productivity.

Health and Safety Hazards on Farms

Farm workers including farm families and migrant workers are exposed to hazards such as the following:

| Danger | Potential Effect or Injury | Prevention |
|-----------------------------|---|--|
| Chemicals/ Pesticides | Skin and respiratory injury or death | Review material safety data sheets (MSDSs) and manufacturers' data sheets, and use proper personal protective equipment (PPE). |
| Cold | Illness, frostbite, or death | Dress properly for the day. |
| Dust | Respiratory injury or explosive combinations | Be aware of your surroundings and activity. |
| Electricity | Shock, burns, fire, or death | Use a qualified professional for wiring dangerous electrical devices. Never overload a circuit. Replace damaged electrical devices or cords. Electrical tape will not insulate you from injury. |
| Grain bins/Silos | Entrapment or suffocation Explosion from formation of dangerous gases and poisoning | Make sure the bin is properly ventilated and maintained. Never "walk the grain." |
| Hand tools | Injury including cuts, abrasions, electrocution, strains, sprains, or death | Make sure hand tools are in good condition. Never leave a damaged tool accessible for someone else to use. |
| Highway traffic | Collisions resulting in injury or death | Follow regulations and stay alert. Avoid alcohol use and the use of communication devices while driving. |
| Lifting/ Lifting devices | Back injury, sprains, or strains Falling material resulting in being struck or crushed by heavy material | Use proper lifting technique. Get help when the load is too heavy. Inspect all lifting chains, straps, or cables routinely to make sure they are in good condition. |
| Livestock handling | Serious injury or death resulting from being pinned, struck, or trampled | Always make sure you have adequate room and an escape route. |
| Machinery/ Equipment | Cuts, abrasions, amputations, or death | Thoroughly read and understand your Owners Equipment Manual (OEM). Never operate the equipment without guards in place. Make sure the equipment can not be energized or otherwise put into operation during repair or maintenance. |
| Manure pits | Suffocation or poisoning Explosion from formation of dangerous gases and poisoning | Keep proper maintenance. |
| Mud | Sprains, strains, entrapment, or suffocation. Eye injury and skin irritation. | Use proper PPE. In some conditions a "spotter" may be needed. |
| Noise | Hearing damage | Use proper PPE. |
| Ponds | Drowning | Put on a life preserver and make sure help is readily available. |
| Slips/Trips/Falls | Sprains, strains, back and neck injury, bone breaks, or death | Keep work area free from clutter and organized. If working on anything elevated, make sure you have appropriate guarding and/or fall protection such as a harness and lanyard. |
| Sun/Heat | Sun burn, heat stroke, shock, or death | Use common sense on excessively hot days. Use sun screen, put on a hat, and stay hydrated. |
| Toxic gases | Skin and respiratory injury or death Explosion | Review MSDSs and manufacturers' data sheets, and use proper PPE. |
| Tractors | Cuts, abrasions, amputations, or death | Thoroughly read and understand your OEM. Never operate the equipment without guards in place or anti-roll over devices. |
| Wells | Electrocution, amputation, or death | Avoid contact with water while working on an electrical device. Make sure the equipment can not be energized or otherwise put into operation during repair or maintenance. Make sure all guarding is in place. |
| Severe weather | Electrocution, "struck by" injuries, or death | Move to a safe place. Lightening, hail, and tornadoes are unpredictable. |

Orthman Manufacturing, Inc. does not limit the potential effects or injuries nor prevention measures to those listed above. They are provided solely as a guideline to making your farm life safer. Always consult your Owner/Operators Manual for specific tool and equipment safety requirements.

Safety Alert Symbol



This safety alert symbol warns of potential hazards to personal safety and that extra precautions must be taken.

When you see this symbol, carefully read the message(s) that follow. Follow all recommended precautions and safe operating practices in this manual.

Hazard control and accident prevention are dependent upon the safety awareness and proper training of personnel involved in the operation of this implement.

Be Aware of Signal Words

Signal words designate a degree or level of hazard seriousness. These signal words include:

DANGER

DANGER indicates a hazardous situation that, if not avoided, will result in death or serious injury. **DANGER** is limited to extreme situations, typically for machine components which for functional purposes cannot be guarded.

WARNING

WARNING indicates a potentially hazardous situation that, if not avoided, could result in death or serious injury. **WARNING** includes hazards that are exposed when safety guards are removed. **WARNING** may also be used to alert against unsafe practices.

CAUTION

CAUTION indicates a potentially hazardous situation that, if not avoided, may result in minor or moderate injury. **CAUTION** may also be used to alert against unsafe practices.

Shutdown and Storage

DANGER

Avoid crushing. Failure to follow this information will result in death or serious injury. Make sure all personnel are clear of the implement before lowering.

Lower the implement to the ground, place the tractor in park, turn off the engine, and remove the key.

DANGER

Avoid crushing. Failure to follow this information will result in death or serious injury. Use bar stands and cylinder stops to support the implement.

Store the implement on a clean, dry, and level surface. An uneven surface could cause the implement to shift or fall, resulting in injury or death as well as implement damage. Securely support all implement components that must be raised. Store the implement away from human activity.

For Your Protection

CAUTION

Read and understand the entire contents of this manual before operating or servicing the implement.

Read and understand all operator manuals for the machinery used in conjunction with the 1975 Toolbar.

Carefully read all safety decals in this manual as well as on the implement. Keep the implement clean so decals are easily visible. Keep all safety decals in good, clean, and legible condition. Immediately replace damaged and/or missing decals. Replacement decals are available from your Orthman dealer.

Learn to operate the implement and all components properly. Do not let others operate the implement without proper instruction. Unauthorized implement modifications may impair function and safety. If you do not understand any content in this manual or need assistance, contact your Orthman dealer.

Equipment Safety Guidelines

Operator safety is the primary concern when designing an Orthman implement. Orthman integrates as many safety features into the implement as possible. You can avoid many hazards and possible accidents by observing precautions in this safety section.

Insist that yourself and personnel working with and around you follow all safety precautions. Be cautious when working with or around the implement to avoid injury.

Safe Transport

Use the following guidelines for safe transport:

- Engage transport locking devices and cylinder stops prior to transport.
- Plan your route to avoid traffic. Yield to traffic in all situations.
- Various conditions will require reduced speed. Travel at speeds that allow for adequate control of stopping and steering.

DANGER

Avoid electrocution. Failure to follow this information will result in death or serious injury. Be aware of overhead power lines.

- Use extreme care when operating the implement near power lines. Contact or close proximity to power lines can result in injury or death.
- Know the transport height and gross weight of the implement. Avoid overhead obstructions not allowing your transport height. Do not use bridges rated below the gross weight of the implement.
- Make sure a slow moving vehicle (SMV) placard is mounted to the implement and is easily visible to other motorists. See “Slow Moving Vehicle (SMV)” on page 2-7.
- Make allowances for implement size when transporting. Sudden braking can cause a towed load to swerve and/or rollover. Never use independent braking with the implement in tow as loss of control and/or rollover can result. Reduce speed if the towed implement is not equipped with brakes.
- Do not coast. Always keep the tractor or towing device in gear to provide engine braking when traveling downhill.
- Comply with state and local laws governing implement transport.

Safe Operation

CAUTION

Read and understand the entire contents of this manual before operating or servicing the implement.

The implement is to be operated by qualified personnel only. Never let children operate the implement. A complete understanding of safety precautions, operation, and maintenance is mandatory before implement use.

DANGER

Avoid electrocution. Failure to follow this information will result in death or serious injury. Be aware of overhead power lines.

Use extreme care when operating the implement near power lines. Contact or close proximity to power lines can result in injury or death.

Know the transport height and gross weight of the implement. Avoid overhead obstructions not allowing your transport height. Do not use bridges rated below your gross weight.

DANGER

Avoid rollover. Failure to follow this information will result in death or serious injury. Do not fold or unfold the implement when on a hillside and avoid sharp turns, as shift of weight could cause rollover.

Operate the implement at a safe distance from terrain irregularities and other obstructions that could cause rollover.

WARNING

Avoid being struck by the implement. Failure to follow this information could result in death or serious injury. Make sure all personnel are clear of the implement at all times when the implement is in motion.

Be aware of obstructions above, below, and around the implement when in operation or transport.

Warning and Safety Lights

Oversized implements and slow moving vehicles create a hazard when transported on public roads. Use safety lighting when traveling on public roads day and night.

Make sure all warning lights, safety lights, and turning signals are working and clean. Replace missing or damaged lights immediately. Comply with state and local laws governing implement safety lighting.

Rear View of Toolbar

See Figure 2-1.

NOTES:

- Two-sided amber lights (2) must be visible from the front and rear of the implement.
- Amber light assemblies (1) must be within 16 in (40.6 cm) of maximum width (6) of the implement.
- Red light assemblies (7) are one-sided and must be visible from the rear of the implement.
- Red light assemblies are centered on the center section between a minimum 48 in (122 cm) and maximum 120 in (305 cm).

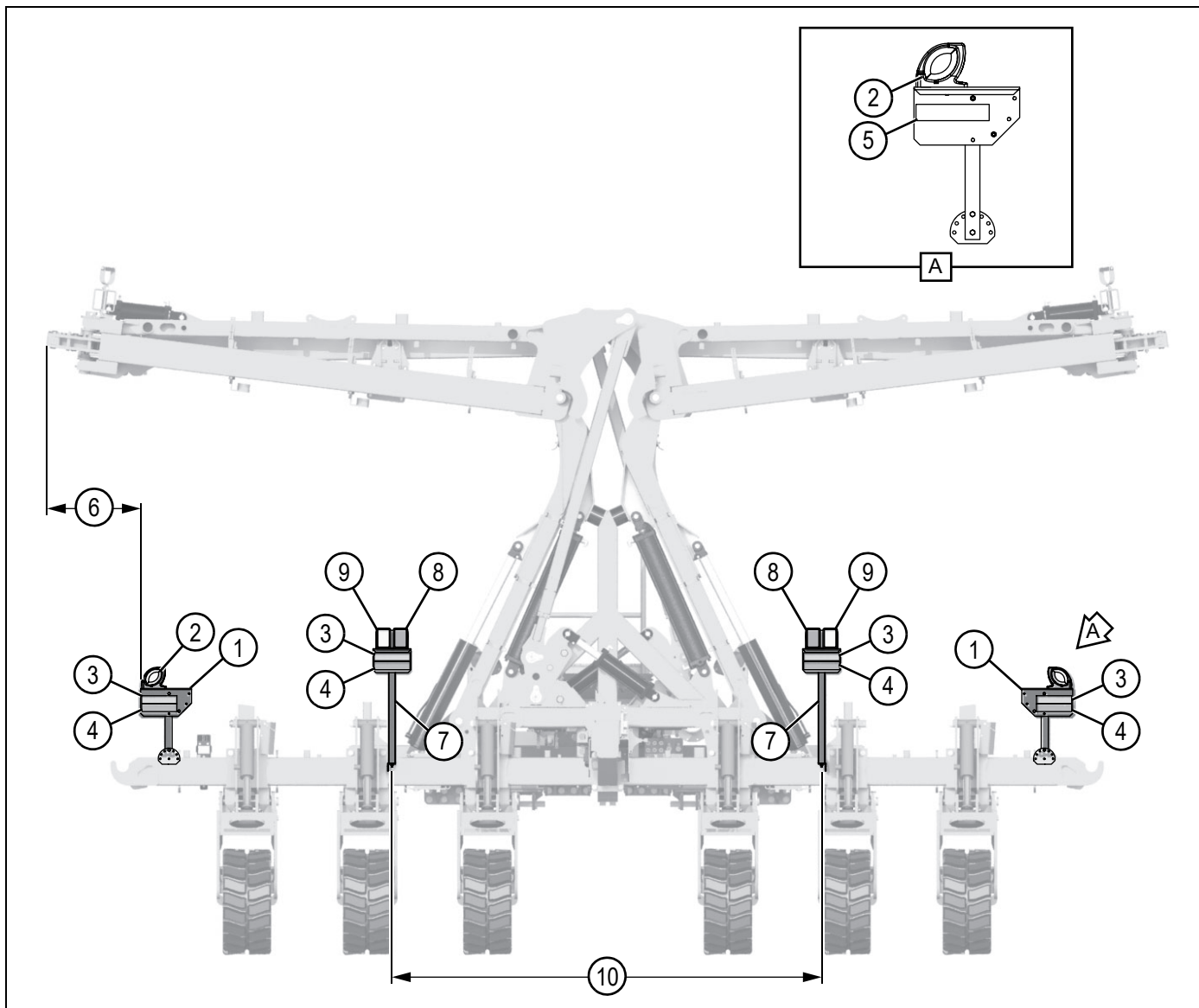

Figure 2-1

ORM000002

- | | |
|---|--------------------------------|
| 1) Amber light assembly (2 used) | 6) Maximum width |
| 2) Two-sided amber light (2 used) | 7) Red light assembly (2 used) |
| 3) Orange fluorescent non-reflective decal (4 used) | 8) Red light (2 used) |
| 4) Red retroreflective decal (4 used) | 9) Amber light (2 used) |
| 5) Amber retroreflective decal (2 used) | 10) Centered width |

Slow Moving Vehicle (SMV)

The slow moving vehicle (SMV) placard (1) is mounted to the implement to alert other motorists that the machine is traveling below posted speed limits. The SMV placard is highly reflective and must be mounted to the implement where it is easily visible to other motorists when the implement is in motion.

Also mounted with the SMV is the speed identification symbol (SIS) (2). The SIS displays the vehicle's max speed in miles per hour (mph) or kilometers per hour (kph).

The SMV and SIS bracket (3) is mounted to the center arm (5) with two bolts (4).

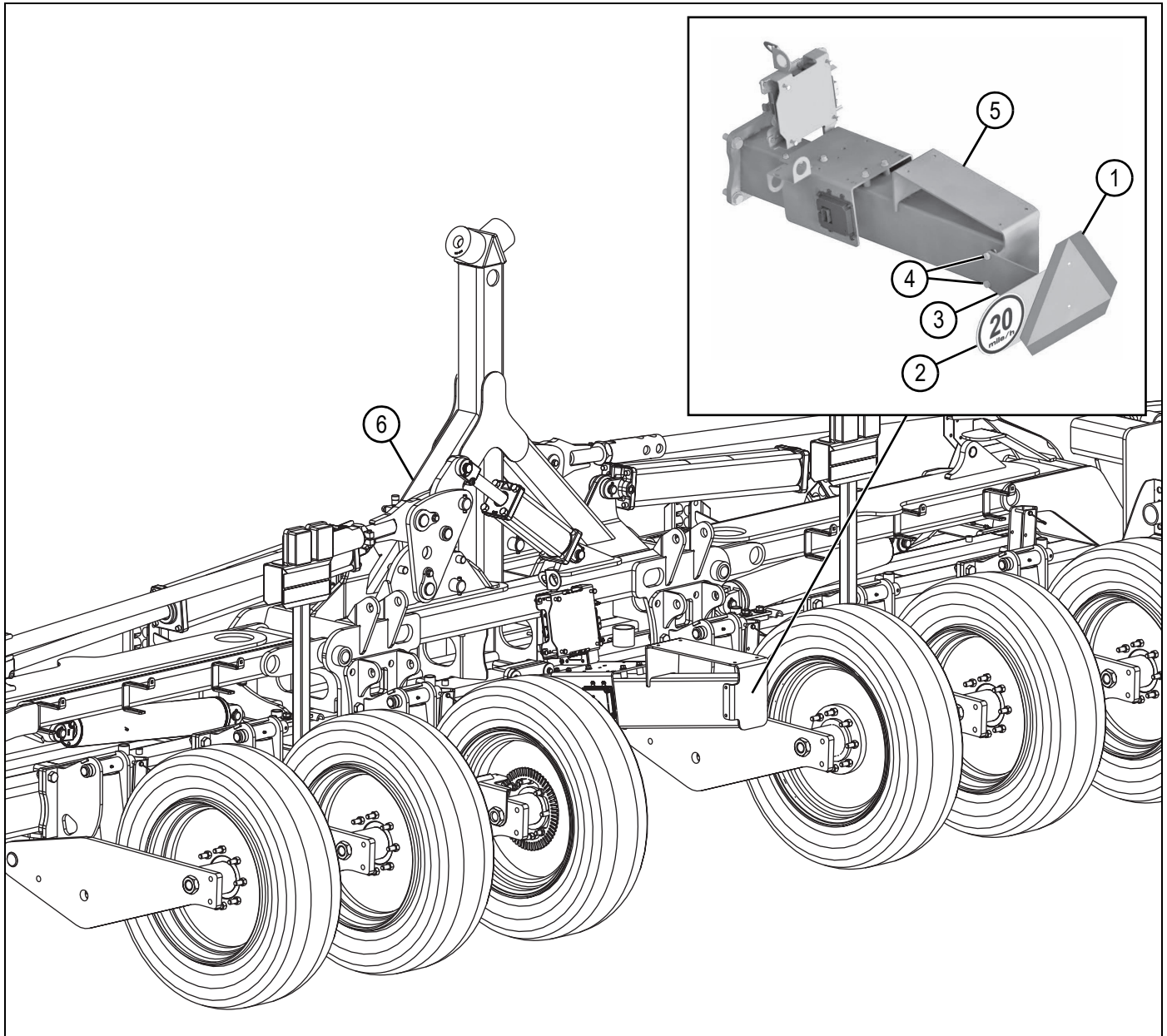

Figure 2-2

ORM00028

1) Slow moving vehicle (SMV) placard
2) Speed identification symbol (SIS)

3) Bracket
4) Bolt (2 used)

5) Center arm
6) Center section

No Riders

⚠ WARNING

Never allow riders on the tractor or implement. Failure to follow this information could result in death or serious injury.

Riders hinder operator visibility and can be thrown from the implement and/or be struck by foreign objects resulting in injury or death.

Practice Safe Maintenance

Proper maintenance is your responsibility. Maintenance neglect and/or poor maintenance practices can result in injury or death. Always use the proper tools to maintain the implement.

⚠ DANGER

Avoid crushing. Failure to follow this information will result in death or serious injury. Make sure all personnel are clear of the implement before lowering.

Lower the implement to the ground, place the tractor in park, turn off the engine, and remove the key.

⚠ DANGER

Avoid crushing. Failure to follow this information will result in death or serious injury. Use bar stands and cylinder stops to support the implement.

Store the implement on a clean, dry, level surface. An uneven surface could cause the implement to shift or fall, resulting in injury or death as well as implement damage. Securely support all implement components that must be raised. Store the implement away from human activity.

⚠ DANGER

Avoid entanglement. Failure to follow this information will result in death or serious injury. Never lubricate or service the implement when in motion.

Keep away from power driven parts when in motion. Disengage power sources prior to maintaining the implement. Injury or death can result from contact with power driven parts when in motion.

⚠ DANGER

Avoid crushing. Failure to follow this information will result in death or serious injury. Do not stand between the tractor and implement when connecting or disconnecting the implement.

Always place the tractor in park and turn off the engine before connecting or disconnecting the implement. Injury or death can result from being trapped between the tractor and implement.

⚠ DANGER

Avoid high-pressure fluid hazards. Failure to follow this information will result in death or serious injury. Relieve hydraulic pressure before servicing or disconnecting hoses.

Escaping pressurized hydraulic fluid can penetrate the skin, resulting in injury or death. Relieve hydraulic system pressure before connecting or disconnecting the tractor.

Never use hands to check for hydraulic leaks. Use cardboard or wood. Wear protective gloves and safety glasses or goggles when working with hydraulic systems. If an accident occurs, see a doctor immediately for proper treatment.

Never operate a combustion engine in an enclosed area. Make sure there is adequate ventilation. Exhaust fumes can cause asphyxiation.

Service tires safely. Tire and rim separation can result in serious injury or death. Do not over inflate tires. Only mount or dismount tires if you possess the proper equipment, otherwise contact a trained professional. Always maintain correct tire pressure. Inspect tires and wheels daily. Do not operate tires with inadequate pressure, cuts, visible damage, or missing hardware.

⚠ CAUTION

Be extremely careful working around unshielded sharp edges. Injury may result from contact with sharp edges.

Keep all parts in good condition and properly installed. Replace damaged or missing parts immediately.

Remove tools and unused parts prior to implement operation.

Prepare for Emergencies

Be prepared for a fire. Keep a readily accessible fire extinguisher at all times.

Keep a readily accessible stocked first aid kit and emergency phone numbers for your doctor, hospital, ambulance, and fire department.

Wear protective clothing and equipment. Wear clothing appropriate for the situation. Protect your eyes, ears, hands, and feet with the use of protective goggles, ear plugs, gloves, boots, etc.

Anhydrous Ammonia (NH₃) and Liquid Fertilizer

⚠ DANGER

Avoid direct exposure to anhydrous ammonia (NH₃) and liquid fertilizer. Failure to follow this information will result in death or serious injury.

Use extreme care when working with anhydrous ammonia (NH₃) and liquid fertilizer.

Keep a clean supply of water readily accessible in case of exposure to NH₃ or liquid fertilizer.

Wear protective goggles and gloves when working with NH₃ or liquid fertilizer. Be sure all persons involved in the operation are properly trained concerning the dangers and precautions involved in the application of NH₃ or liquid fertilizer.

If you choose to apply NH₃ or liquid fertilizer, it is advisable to consult documented information regarding safe handling and application of NH₃ or liquid fertilizer. Information is available from the following recognized sources:

- American National Standards Institute (ANSI): www.ansi.org - (212) 642-4900
- Material Safety Data Sheets (MSDS): www.msds-online.com
- National Safety Council: www.nsc.org/necas
- The Fertilizer Institute: www.tfi.org
- United States Department of Transportation (USDOT): www.dot.gov
- Compressed Gas Association: www.cganet.com

Safety Never Hurts

⚠ CAUTION

Read and understand the entire contents of this manual before operating or servicing the implement.

Use the following safety practices:

- Understand all implement functions.
- Never stand between the tractor and implement when connecting or disconnecting the implement.
- Be aware of all surroundings before you move the implement.
- Operate the implement from operator's seat only.
- Never mount or dismount a moving tractor.
- Never leave the engine running when the implement is unattended.
- Keep away from power driven parts when in motion.
- Make sure all personnel are clear before lowering implement to the ground.

Orthman Serial Number Plate

The Orthman serial number plate contains valuable information. The model number (1) and serial number (2) provide Orthman dealers and the Orthman service department with the exact specifications of your implement if any warranty or service issues need to be addressed.

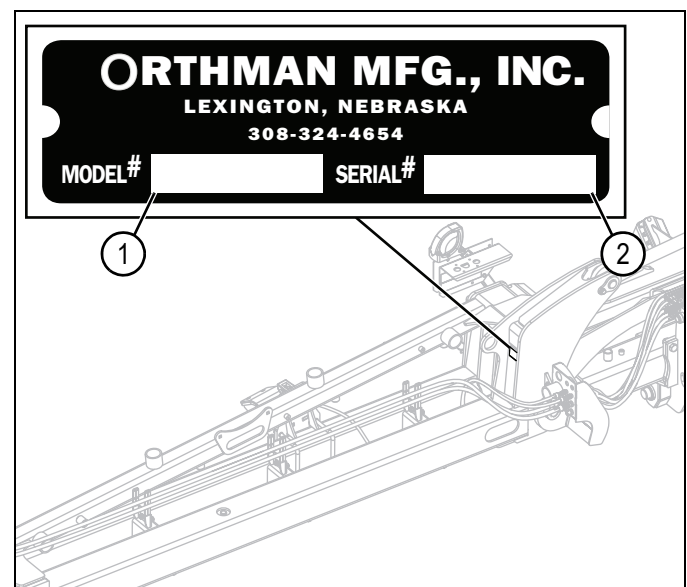

Figure 2-3

ORM000001

1) Model number

2) Serial number

Safety Decals

Safety decals promote awareness and knowledge concerning safe operation and maintenance of the implement. Carefully read all safety decals in this manual as well as on the implement.

Keep the implement clean so decals are easily visible. Keep all decals in good and legible condition. Immediately replace damaged and/or missing decals.

NOTE: Replacement decals are available from your Orthman dealer. When replacing decals, thoroughly clean the area where the decal is to be placed and attach the decal void of bubbles.

Orthman Center Decals

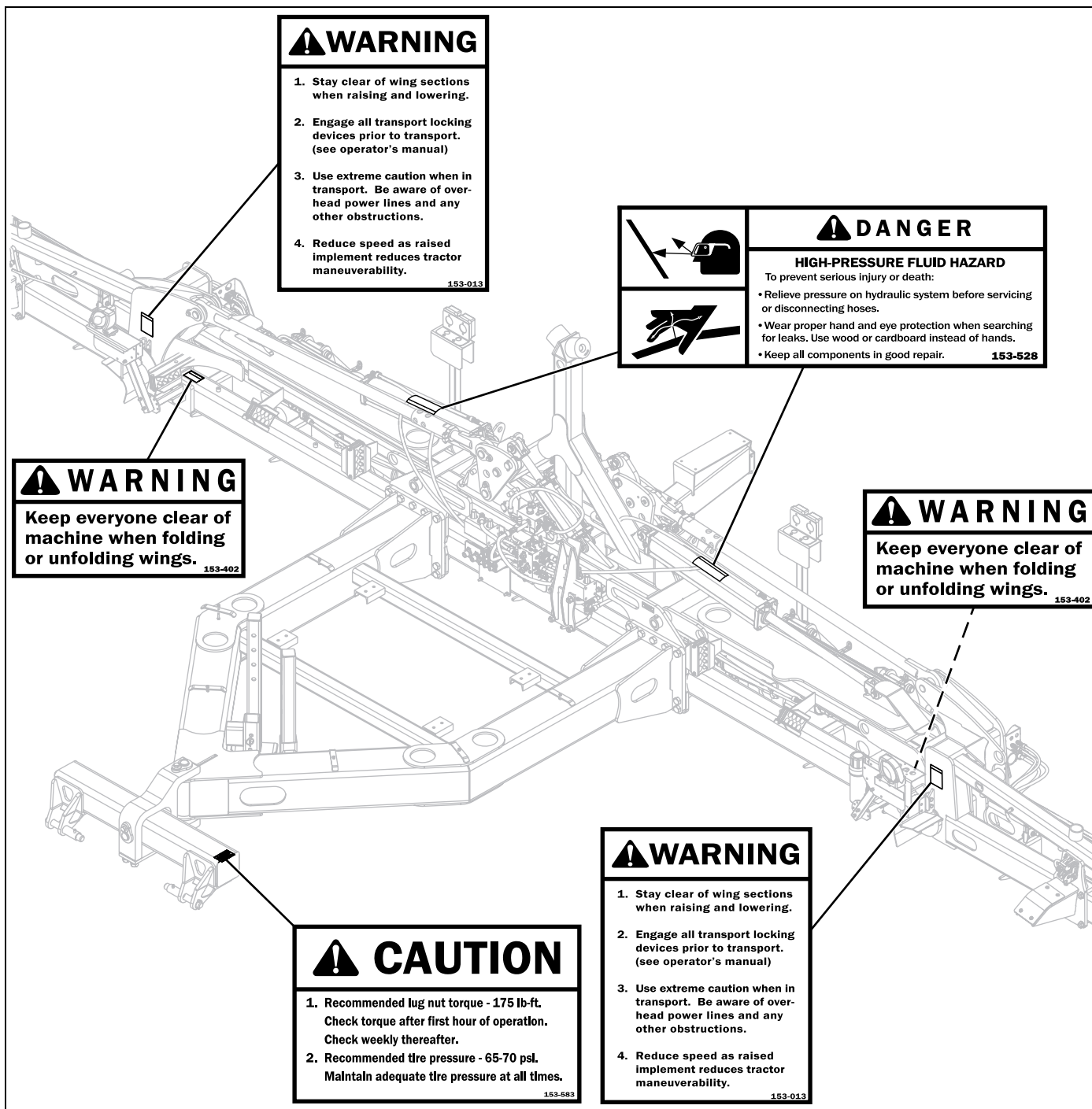

Figure 2-4

ORM000006

Orthman Wing Decals

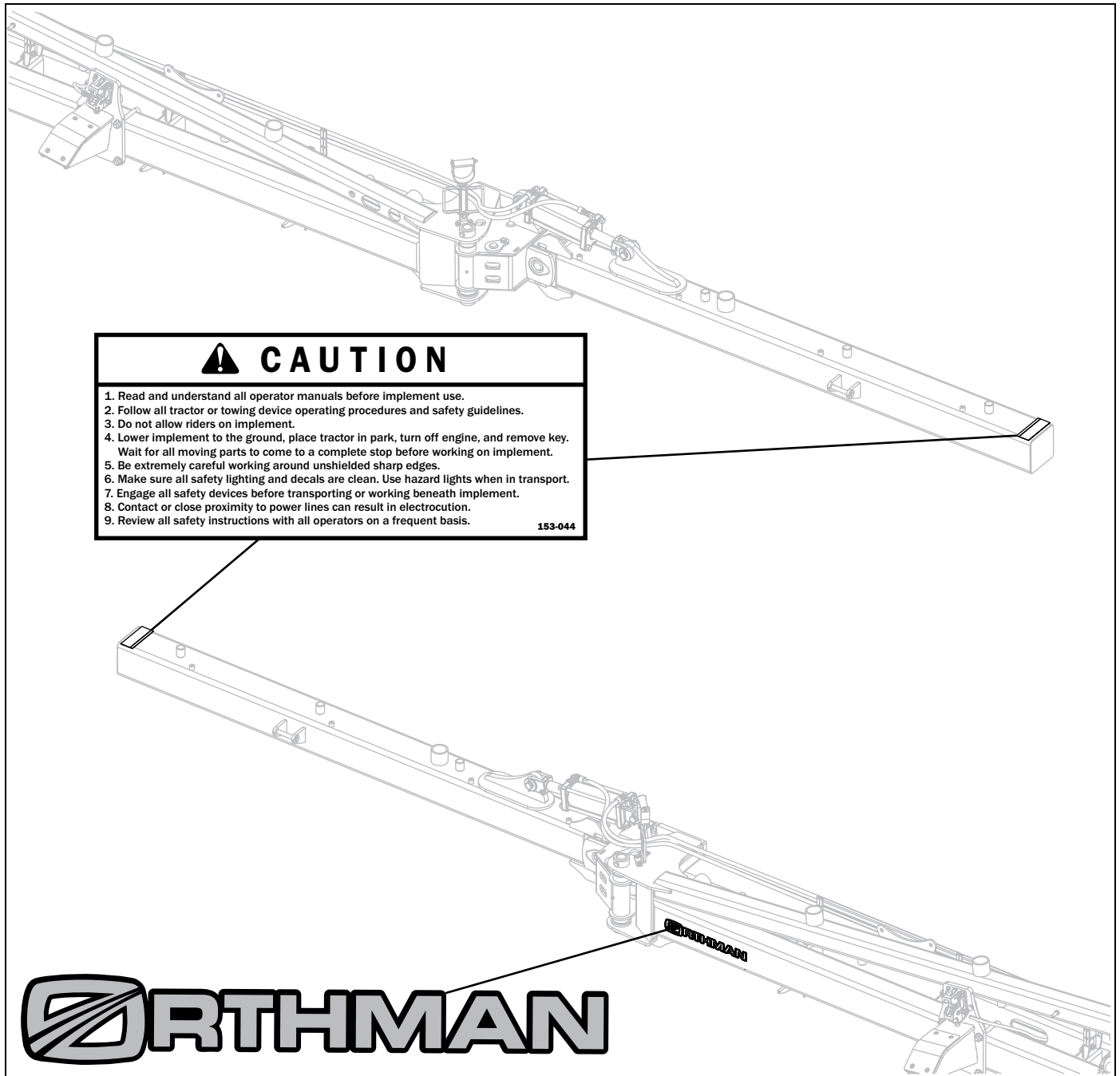

Figure 2-5

ORM000005

Page Intentionally Blank

Chapter 3

Major Components

| | |
|---|-----|
| Center | 3-2 |
| Wing | 3-3 |
| Lift Wheel | 3-4 |
| Lift Track | 3-5 |
| Tongue and Hitch | 3-6 |
| Central Commodity System (CCS) Planter Tongue and Hitch | 3-7 |

Center

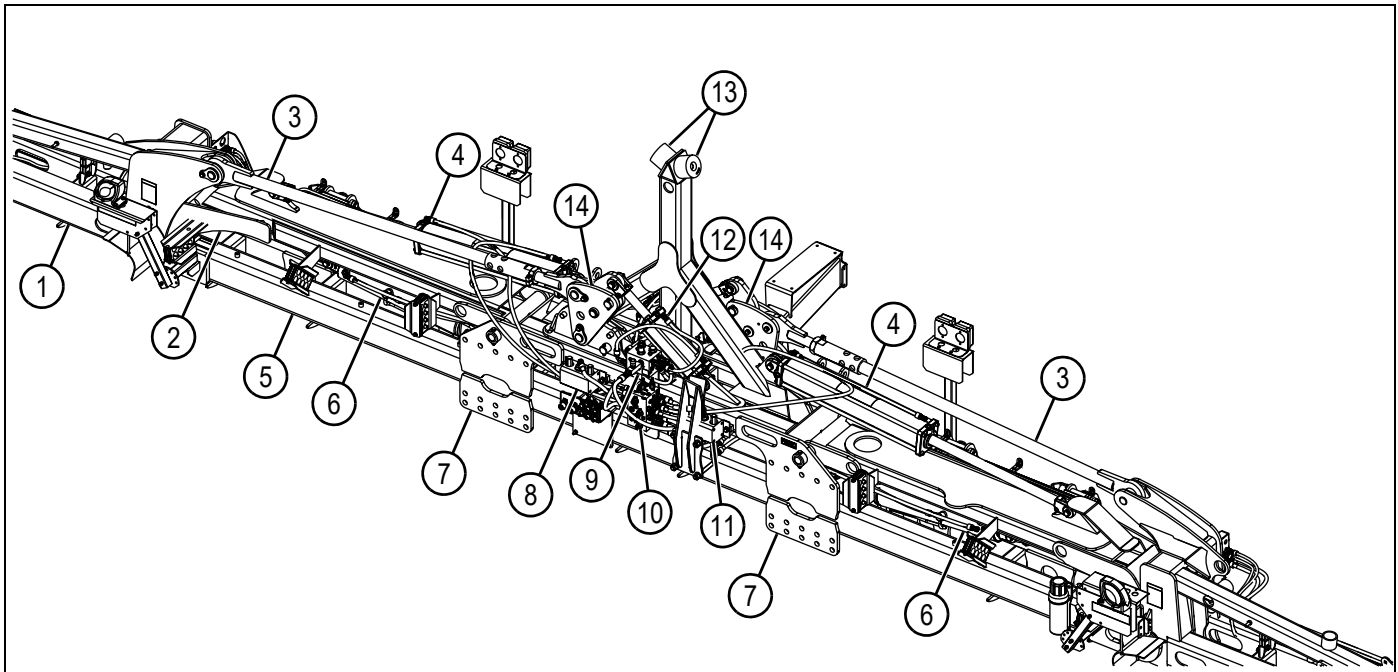

ORM000004

Figure 3-1

- | | | |
|---------------------------------|--------------------------------------|--------------------------------------|
| 1) Midwing (2 used) | 6) Secondary stack cylinder (2 used) | 11) Stack cylinder flow divider |
| 2) Swing truss (2 used) | 7) Tongue connection plate (2 used) | 12) Gullwing/float cylinder (2 used) |
| 3) Strut (2 used) | 8) Lift wheel flow divider | 13) Wing rest bumper (2 used) |
| 4) Main stack cylinder (2 used) | 9) Gullwing manifold | 14) Gullwing assembly (2 used) |
| 5) Center section | 10) Fold control manifold | |

Wing

NOTE: Left midwing and outer wing shown. Right midwing and outer wing are similar.

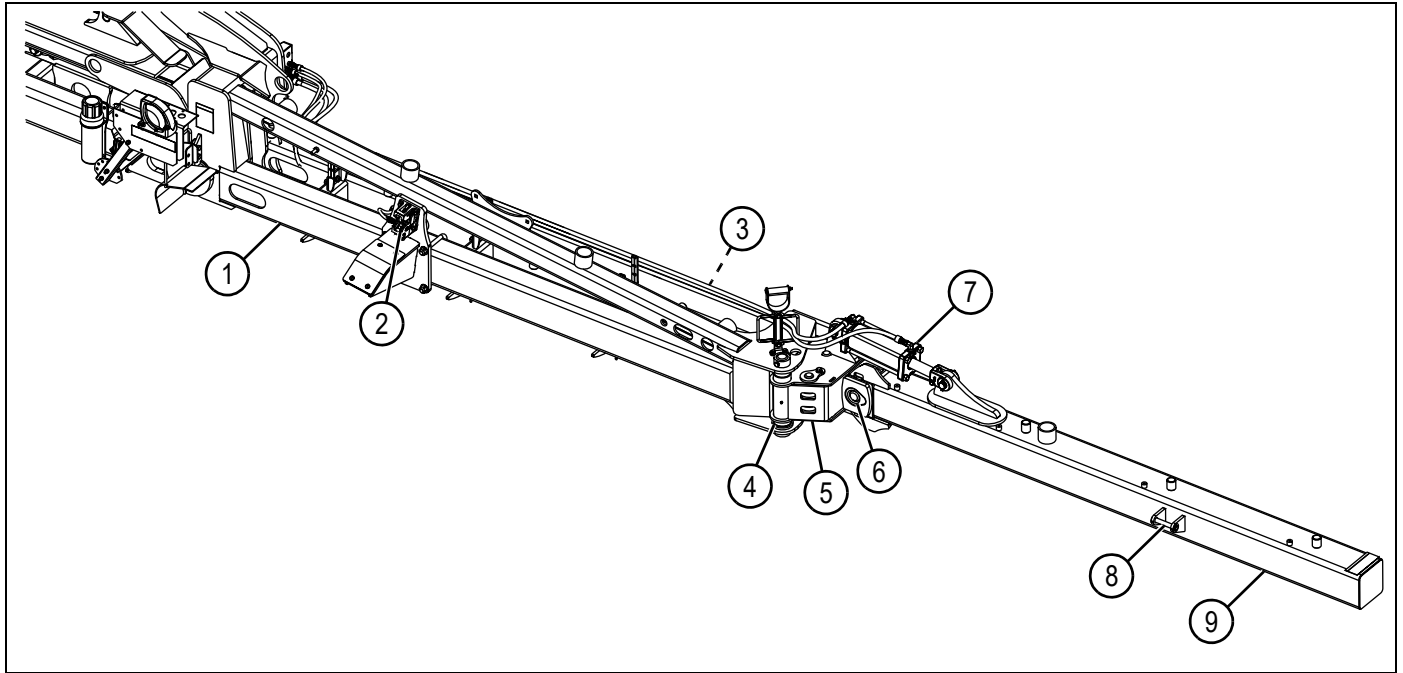

Figure 3-2

ORM000003

- | | | |
|------------------------------|----------------------------|--------------------------------|
| 1) Midwing | 4) Pivot point (in/out) | 7) Outer wing up/down cylinder |
| 2) Outer wing latch assembly | 5) Outer wing fold linkage | 8) Outer wing latch pin |
| 3) Outer wing fold cylinder | 6) Pivot point (up/down) | 9) Outer wing |

Lift Wheel

NOTE: Left side lift wheels shown. Right side lift wheels are similar.

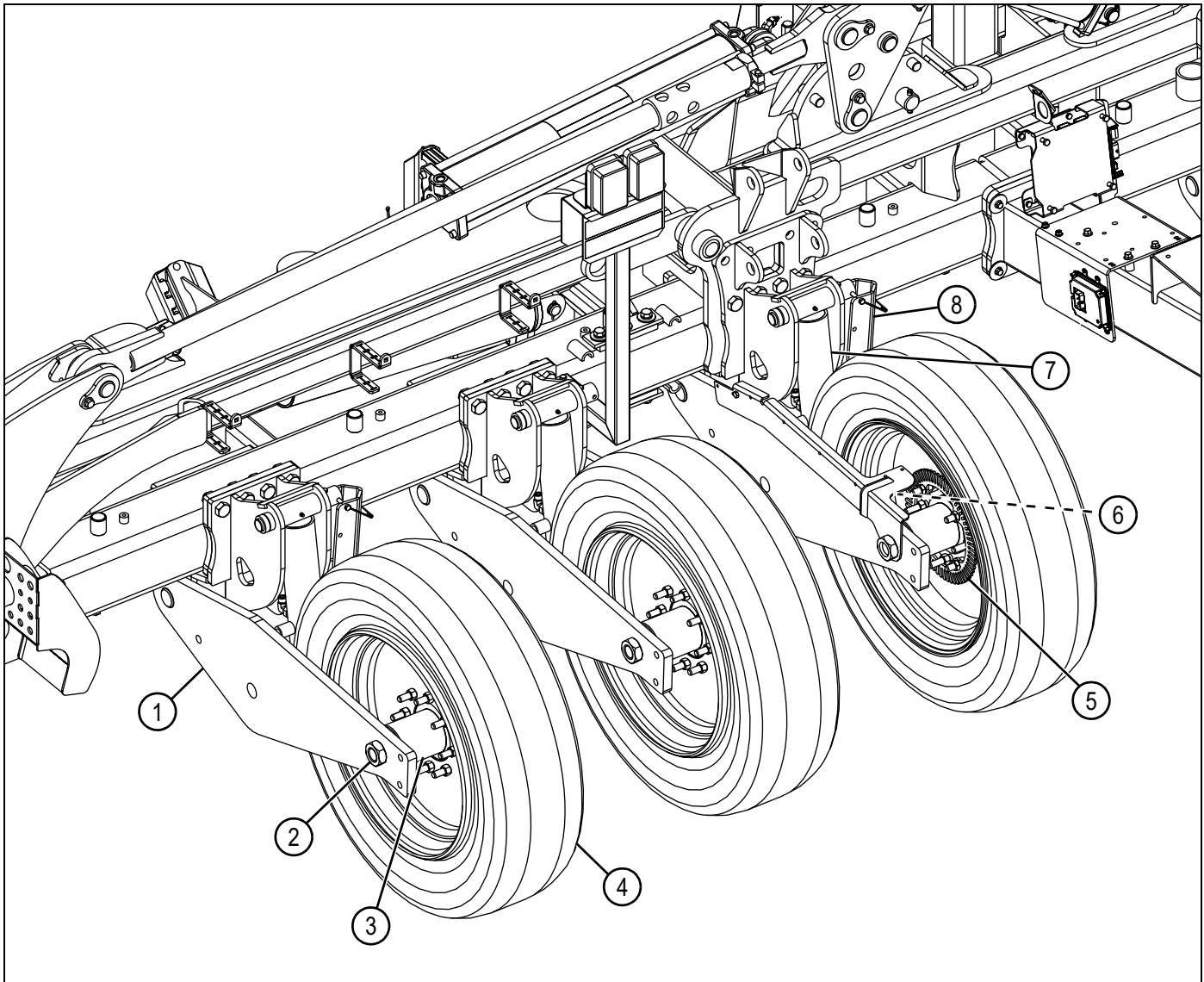

Figure 3-3

ORM00014

- | | | |
|----------------------------|--|-----------------------------------|
| 1) Lift arm yoke (6 used) | 4) Lift wheel tire and rim assembly (6 used) | 7) Lift wheel cylinder (6 used) |
| 2) Axle bolt (6 used) | 5) Motion wheel | 8) Safety transport lock (4 used) |
| 3) Lift wheel hub (6 used) | 6) Motion sensor | |

Lift Track

NOTE: Left side lift tracks shown. Right side lift tracks are similar.

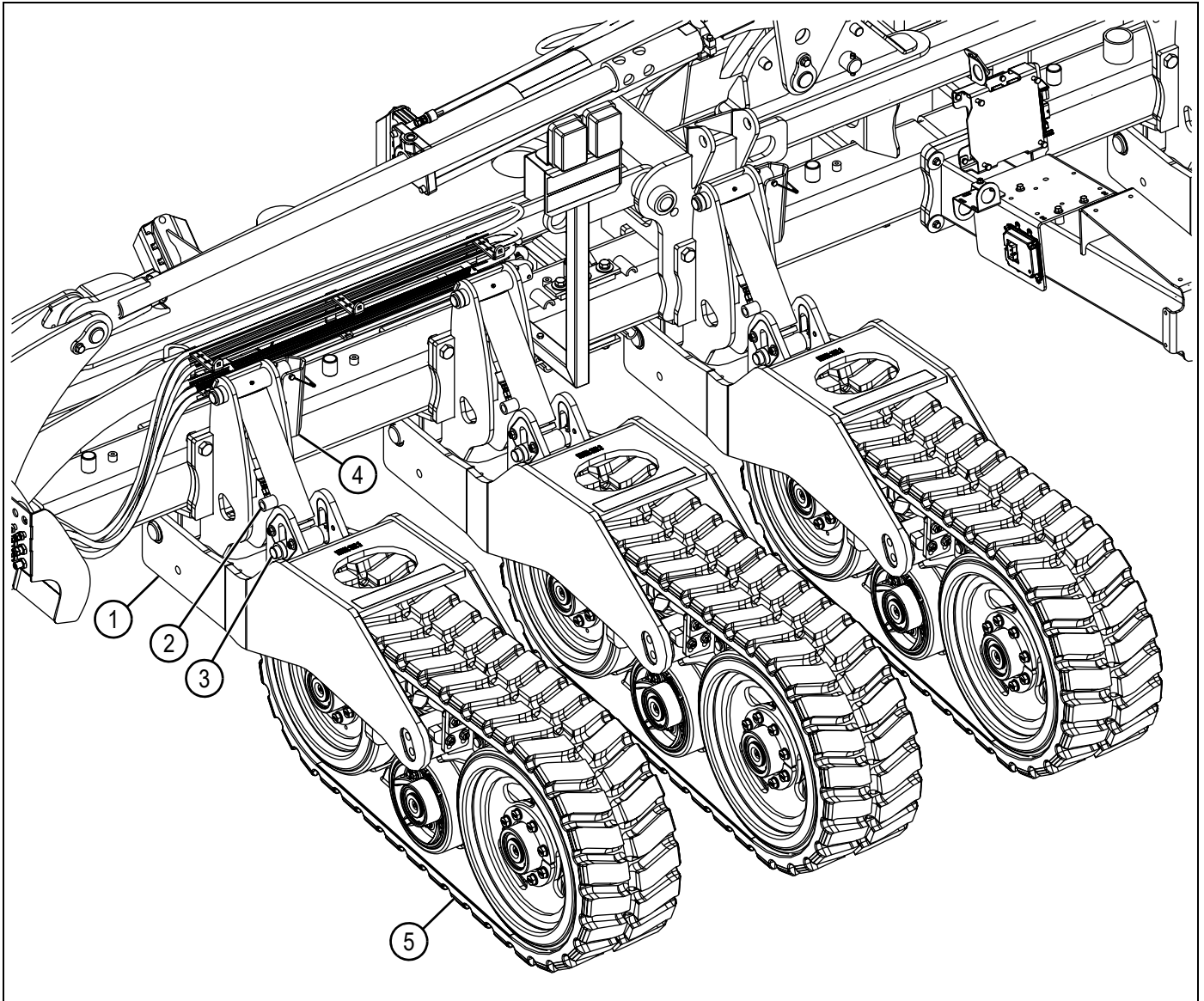

Figure 3-4

ORM00015

- | | | |
|---------------------------------|-------------------------------------|-------------------|
| 1) Lift arm yoke (6 used) | 3) Height adjustment block (6 used) | 5) Track (6 used) |
| 2) Lift track cylinder (6 used) | 4) Safety transport lock (4 used) | |

For more information on the tracks, contact a Soucy dealer.

Tongue and Hitch

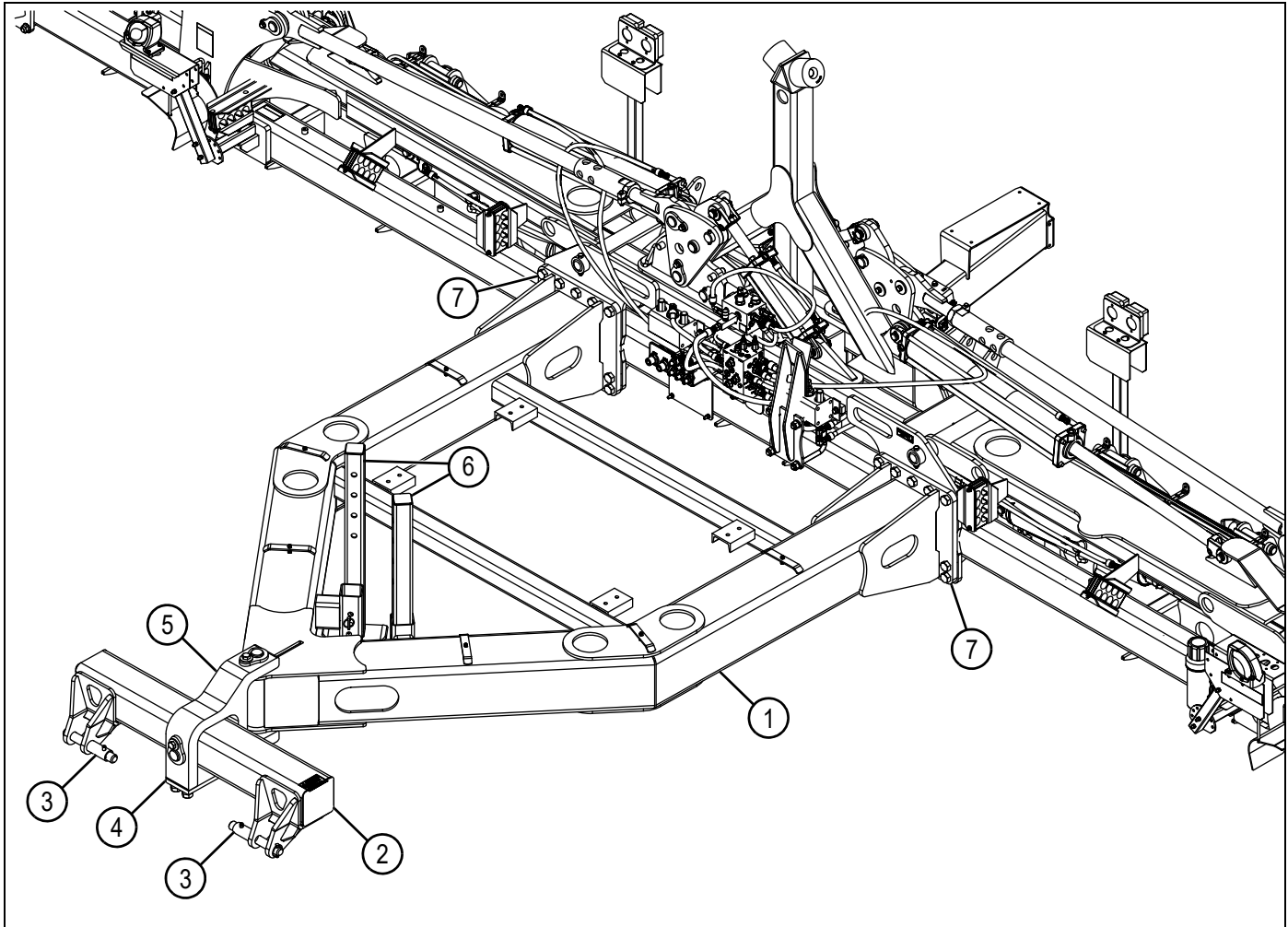

Figure 3-5

ORM00007

- | | | |
|-----------------------|-------------------------------|------------------------------|
| 1) Tongue | 4) Hitch knuckle bottom plate | 6) Bar stand (2 used) |
| 2) Hitch | 5) Hitch knuckle | 7) Connection plate (2 used) |
| 3) Hitch pin (2 used) | | |

Central Commodity System (CCS) Planter Tongue and Hitch

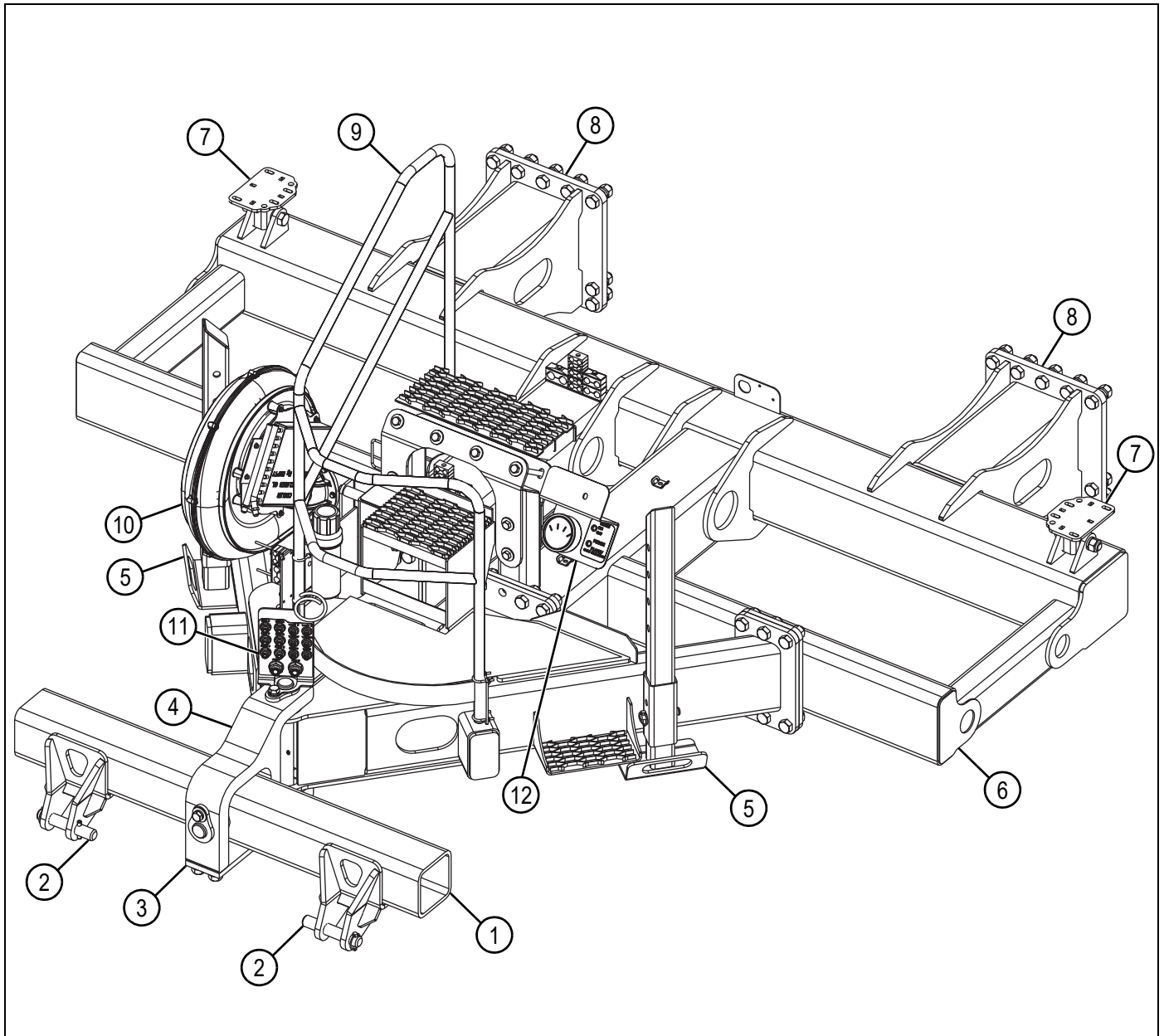

Figure 3-6

ORM000010

- | | | |
|-------------------------------|--|----------------------------|
| 1) Hitch | 5) Bar stand (2 used) | 9) Handrail |
| 2) Hitch pin (2 used) | 6) Central commodity system (CCS) tongue | 10) CCS blower |
| 3) Hitch knuckle bottom plate | 7) CCS cradle support tube (2 used) | 11) Hydraulic bulkhead |
| 4) Hitch knuckle | 8) Connection plate (2 used) | 12) Gauge and switch plate |

Page Intentionally Blank

Chapter 4

Preparation and Setup

| | |
|--|------|
| Preparing the Toolbar | 4-2 |
| Implement-to-Tractor Connection | 4-3 |
| Disconnecting Implement From Tractor | 4-4 |
| Outer Wing Fold | 4-5 |
| Outer Wing Latch | 4-6 |
| Gullwing Kit | 4-7 |
| Plumbing the Gullwing Kit | 4-7 |
| Leveling the Midwings | 4-8 |
| Fold Control Manifold | 4-10 |
| Manifold Connections | 4-10 |
| Front Side of Manifold | 4-10 |
| Right Side of Manifold | 4-11 |
| Left Side of Manifold | 4-11 |
| Adjusting the Fold Control Manifold | 4-12 |
| Adjust the Counterbalance Valves | 4-12 |
| Adjust the Sequence Valves | 4-13 |
| Implement Guidance | 4-14 |

CAUTION

Do not attempt to fold the toolbar until you have read **Chapter 4, “Preparation and Setup”**. Failure to follow this information may result in minor or moderate injury or cause implement damage.

Preparing the Toolbar

1. Make sure that all decals are in good, clean, and legible condition. Make sure each decal is correctly placed according to the safety section of this operator’s manual. See “Safety Decals” on page 2-10 for more information.
2. Make sure that the hydraulic system of the tractor is in working order. Orthman 1975 Toolbar hydraulic systems are designed for a 3000 psi (207 bar) system.
3. Make sure that the hydraulic tips and outlets are free of foreign material. Foreign material can ruin hydraulic components, which results in adverse toolbar operation.
4. Be sure toolbar float link and gullwing pins are in the proper position. Pin position for toolbar transport differs from recommended pin position for field use. See “Gullwing Feature and Toolbar Float” on page 5-2.

CAUTION

It is not recommended to stack the toolbar without folding the outer wing. Failure to follow this information may result in minor or moderate injury or cause implement damage.

DANGER

Avoid rollover. Failure to follow this information will result in death or serious injury. Stacking one wing at a time causes the center of gravity to shift. This results in rocking and unbalanced equipment. Use extreme caution when you move unbalanced equipment, as the tractor and implement are more likely to tip.

5. Before folding the toolbar, review “Outer Wing Fold” on page 4-5. If the toolbar is not folding in the proper sequence, see “Adjusting the Fold Control Manifold” on page 4-12.
6. Be sure the lift wheel tire pressure is 65–70 psi (4.5–4.8 bar).
7. Tighten lift wheel lug nut to 175 lb-ft (237 N•m). After first hour of operation check torque again; then check weekly thereafter.
8. For lift track option, see Soucy operator’s manual for more information on proper track set-up.
9. Be sure to lubricate all grease points on machine. See “Lubrication” on page 7-3.

DANGER

Avoid high-pressure fluid hazards. Failure to follow this information will result in death or serious injury. Relieve hydraulic pressure before servicing or disconnecting hoses.

10. Relieve hydraulic system pressure before connecting or disconnecting the tractor. Attach hydraulic hoses to the tractor according to the operator preferences.
11. Before field operation, remove float link from the rigid position. See “Gullwing Feature and Toolbar Float” on page 5-2.
12. Before each use, check all hardware for wear and the proper torque. Replace missing hardware with hardware of an identical grade in order to restore the implement to original specifications.

Implement-to-Tractor Connection

The 1975 Toolbar has a Category 3 two-point hitch. Category 3N, 4, or 4N hitches are available. Contact the Orthman service department for details.

See the tractor operator's manual for more information on properly connecting the implement.

NOTE: *It is not recommended to use the tractor's three-point hitch quick coupler for connecting the machine to the tractor.*

The tractor's hydraulic system must be able to support 3000 psi (207 bar) of working pressure, and have a minimum 2250 psi (155 bar). The hydraulic system capacity should be 2 gal (7.5 L) minimum.

⚠ DANGER

Avoid crushing. Failure to follow this information will result in death or serious injury. Make sure all personnel are clear of the implement before lowering.

⚠ DANGER

Avoid crushing. Failure to follow this information will result in death or serious injury. Do not stand between the tractor and implement when connecting or disconnecting the implement.

1. Back up tractor to the implement hitch. Place the tractor in park, turn off the engine, and remove the key before connecting the implement. Injury or death can result from being trapped between the tractor and implement.
2. Set tractor's three-point hitch lift links. Hitch lift links should be adjusted to the operating depth dimensions indicated in the tractor operator's manual.
3. Set tractor's three-point hitch lateral float pins. Lateral float pins should be placed in the lower holes to allow machine to float and follow the ground surface.
4. Set tractor's three-point hitch sway blocks. Sway blocks and bumpers should be installed if no implement guidance is being utilized with machine.
5. Connect the lower tractor three-point hitch (1) points to the swivel hitch (2) on the implement tongue at the hitch pins (3).

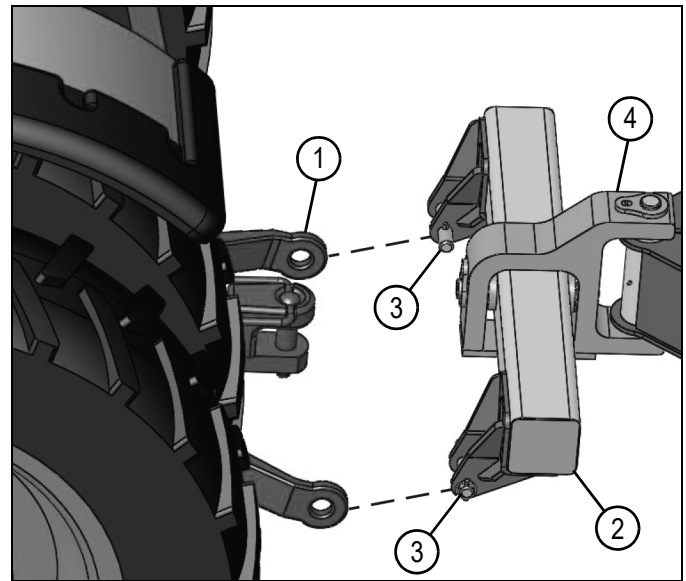

Figure 4-1

ORM000012

- | | |
|----------------------|-----------------------|
| 1) Three-point hitch | 3) Hitch pin (2 used) |
| 2) Hitch | 4) Hitch knuckle |

⚠ DANGER

Avoid high-pressure fluid hazards. Failure to follow this information will result in death or serious injury. Relieve hydraulic pressure before servicing or disconnecting hoses.

6. Relieve hydraulic system pressure before connecting the tractor. Attach hydraulic hoses to the tractor according to the operator preferences. Hydraulic hoses are labeled on the bulkhead on the tongue. See "Hydraulic Bulkhead Connections" on page 5-4.
7. Attach toolbar controller electrical connections and toolbar safety lights to the tractor.
8. Make sure all electrical and hydraulic lines are plumbed over the hitch to the tractor to avoid wear or damage.
9. Raise the tongue bar stands to highest point and install stay pins.

Disconnecting Implement From Tractor

See the tractor operator's manual for more information on properly disconnecting the implement.

1. Park implement on a clean, level surface; strong enough to support the weight of the machine.
2. Unfold the toolbar. See "Outer Wing Fold" on page 4-5.
3. Install the float link lock pins (1) into the float link rigid position to lock the wings in the rigid position. The gullwing hydraulic cylinders (2) must be partially extended to align pin holes in the wing float link plates (3). Lower the machine to enable the gull wing hydraulic cylinders to lower the wings down.

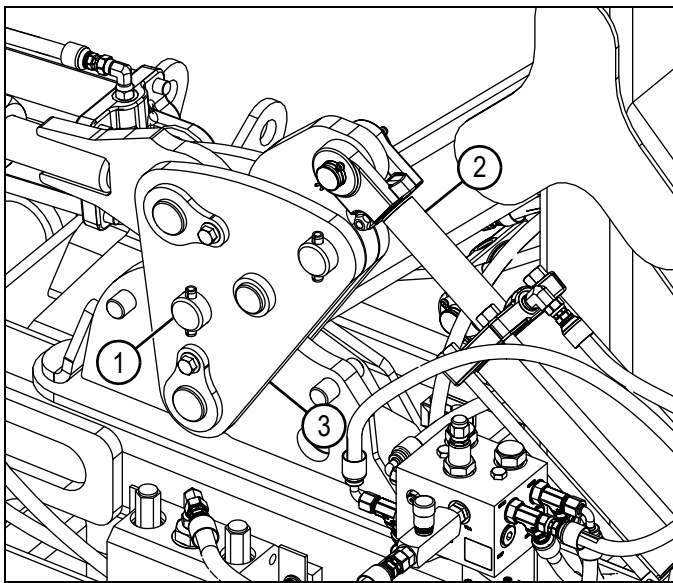

Figure 4-2: Right Gullwing

- | | |
|---|--------------------------------------|
| 1) Float link lock pin (2 used) | 3) Wing float link plate (4 used) |
| 2) Gullwing hydraulic cylinder (2 used) | |

⚠ DANGER

Avoid crushing. Failure to follow this information will result in death or serious injury. Use bar stands and cylinder stops to support the implement.

4. Install the safety transport locks (4) around the machine lift hydraulic cylinder rods (5).

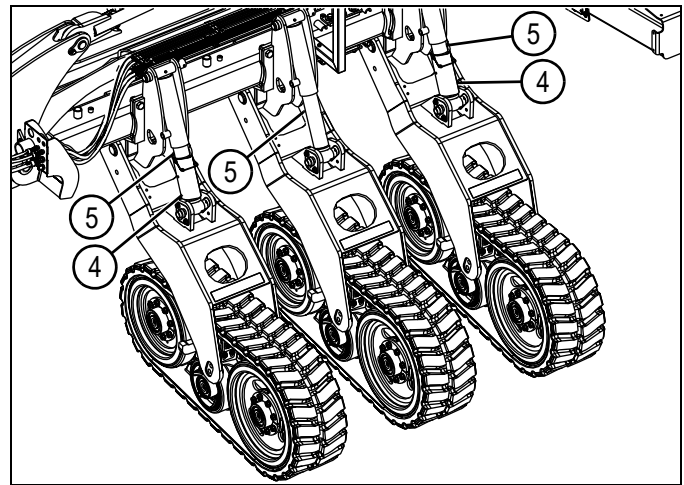

Figure 4-3

ORM000030

- | | |
|--------------------------------------|---------------------------------------|
| 4) Safety transport lock (4 used) | 5) Hydraulic cylinder rod (6 used) |
|--------------------------------------|---------------------------------------|
5. Lower the tongue bar stands and install stay pins.

⚠ DANGER

Avoid crushing. Failure to follow this information will result in death or serious injury. Make sure all personnel are clear of the implement before lowering.

6. Lower machine onto safety transport locks and lower the tongue onto the tongue stands by placing the tractor three-point hitch and machine lift hydraulic cylinders into the float position.

⚠ DANGER

Avoid crushing. Failure to follow this information will result in death or serious injury. Do not stand between the tractor and implement when connecting or disconnecting the implement.

7. Place the tractor in park, turn off the engine, and remove the key before disconnecting the implement.

⚠ DANGER

Avoid high-pressure fluid hazards. Failure to follow this information will result in death or serious injury. Relieve hydraulic pressure before servicing or disconnecting hoses.

8. Relieve hydraulic system pressure before disconnecting the tractor. Disconnect hydraulic hoses from tractor selective control valve (SCV).
9. Disconnect all machine electrical connections from tractor.
10. Disconnect tractor three-point hitch draft links from the machine tongue hitch tugs.

Outer Wing Fold

During the fold process, the outer wing up/down cylinder (1) retracts and flexes the outer wing (3) up 8° before folding inward.

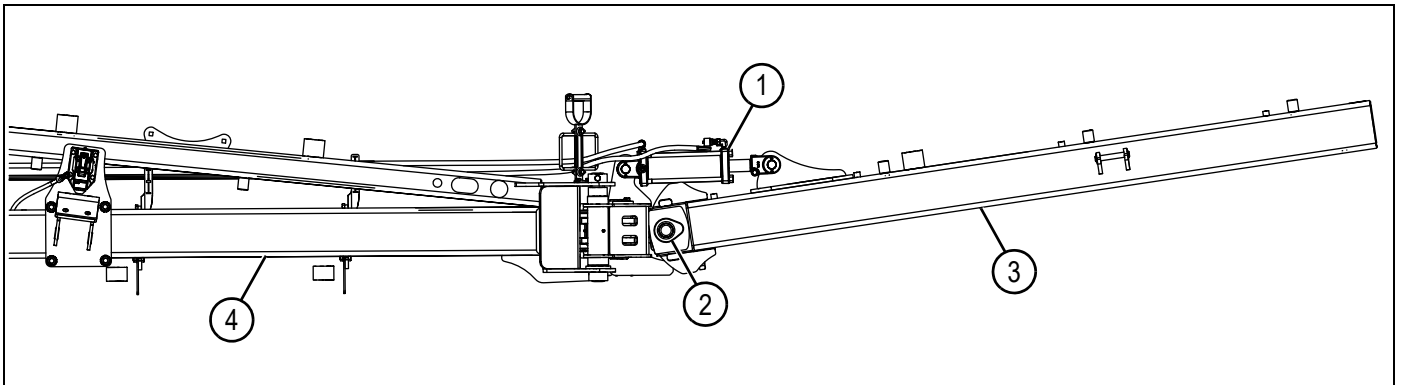

Figure 4-4

ORM000026

- 1) Outer wing up/down cylinder 2) Pivot point 3) Outer wing 4) Midwing

The outer wing (3) fold mechanism is comprised of a single cylinder and fold linkage (5). The outer wing fold cylinder (6) is mounted internally in the midwing (4) and connected to the fold linkage.

As the outer wing fold cylinder (6) extends, the fold linkage (5) pivots and folds the outer wing (3). As the cylinder retracts, the fold linkage pivots and unfolds the outer wing.

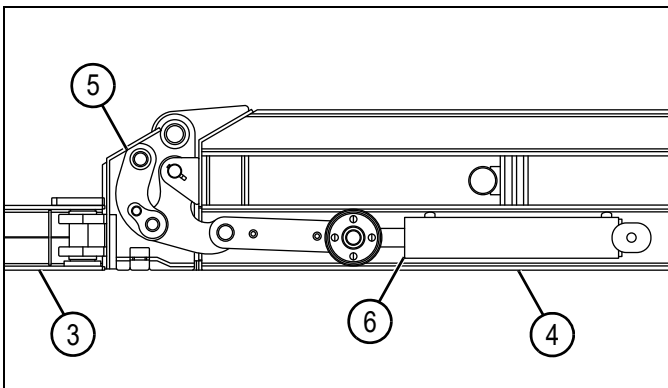

Figure 4-5: Top View Cutaway

ORM000027

- 3) Outer wing 5) Fold linkage
4) Midwing 6) Outer wing fold cylinder

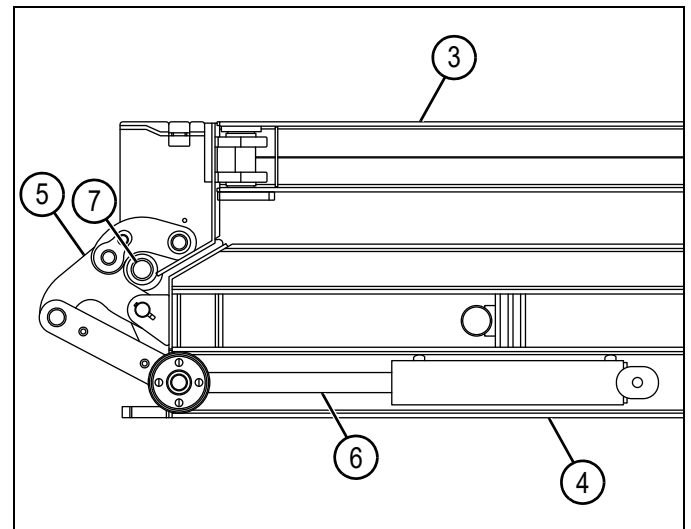

Figure 4-6: Top View Cutaway

ORM000008

- 3) Outer wing 6) Outer wing fold cylinder
4) Midwing 7) Pivot point
5) Fold linkage

Outer Wing Latch

When in the folded position, a latch holds the outer wing (3). The outer wing latch assembly (2) will prevent the wing from swinging freely if hydraulic pressure is lost while transporting the toolbar. The latch assembly works automatically and is controlled by hydraulics.

During the folding process, the outer wing raises and swings inward. As latch pin (4) on the outer wing meets the latch plate on the midwing (1), the latch rotates open and then closes on the latch pin when the wing is fully folded. When the wing is unfolded, hydraulics rotate the latch assembly open before the wing unfolds.

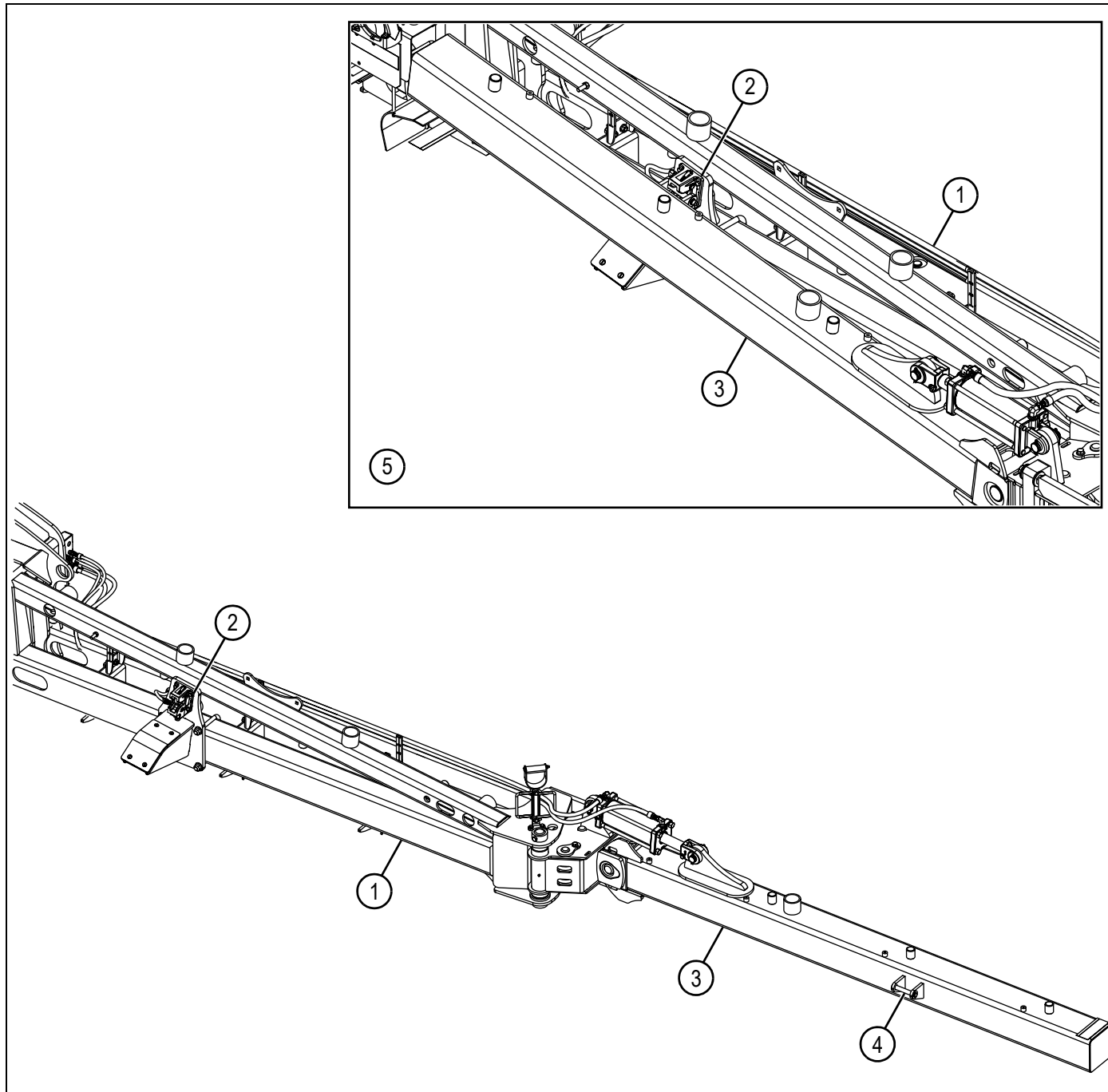

Figure 4-7

ORM000009

- 1) Midwing
- 2) Outer wing latch assembly
- 3) Outer wing
- 4) Latch pin
- 5) Outer wing folded and latched

Gullwing Kit

A gullwing kit is standard equipment on the 1975 Toolbar. The gullwing kit allows the toolbar wings to flex up and down over varying field conditions and to be tipped up for added clearance during end-row turns. There is a gullwing kit for each midwing.

For more information on the gullwing operation, see "Gullwing Feature and Toolbar Float" on page 5-2.

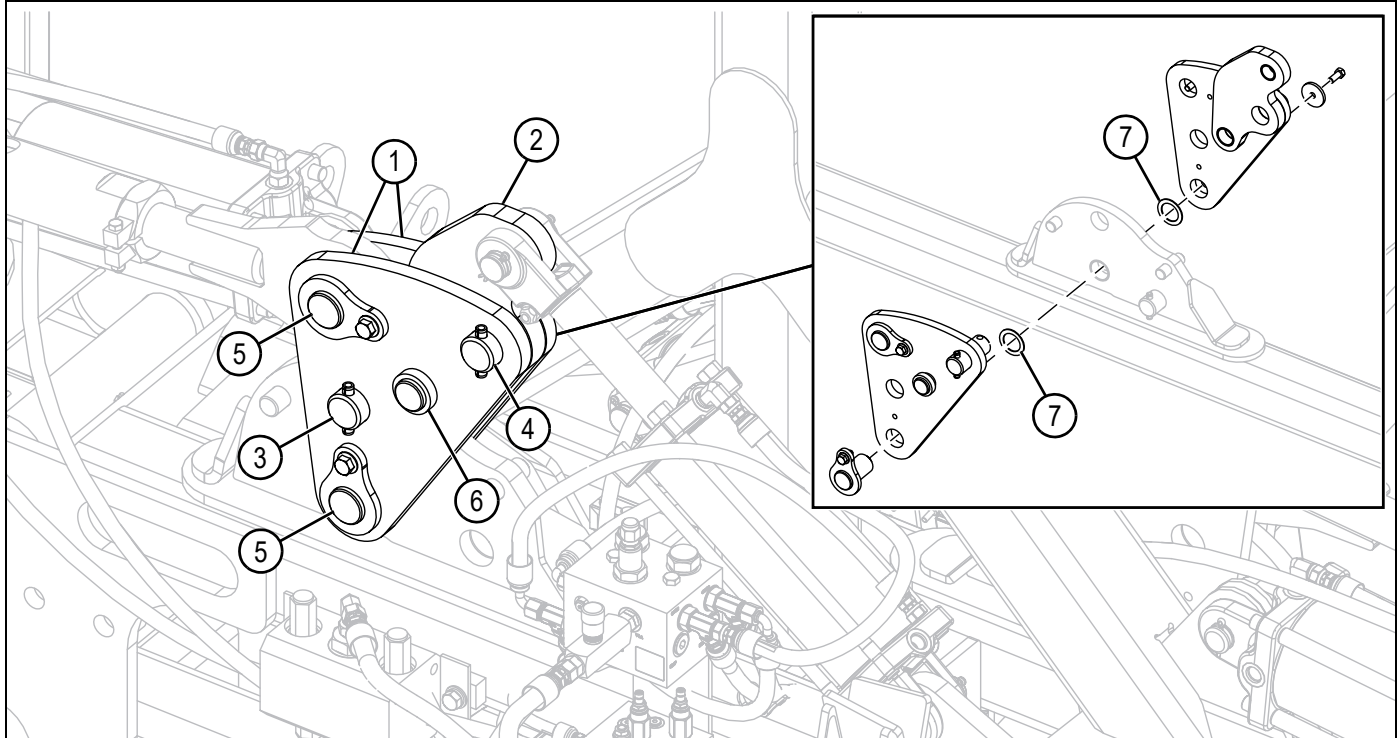

Figure 4-8: Right Gullwing Kit

ORM00011

- | | | |
|-----------------------------------|--------------------------|--------------------|
| 1) Wing float link plate (2 used) | 4) Gullwing pin position | 6) Centering pin |
| 2) Gullwing link plate | 5) Pin (2 used) | 7) Washer (2 used) |
| 3) Float link rigid position | | |

Plumbing the Gullwing Kit

The gullwing cylinders are plumbed double-acting. The rod end cylinder hose is connected to the return side of the gullwing manifold. The base end cylinder hose is connected to the supply side of the gullwing manifold. The gullwing manifold connects to the fold control manifold.

The gullwing cylinders are connected to the same circuit as the outer wing up/down cylinders for simultaneous operation. The gullwing cylinders and outer wing up/down cylinders are controlled by the gullwing manifold. Because of this, you must place the outer wing and gullwing hydraulics in float during field operation. This ensures the proper performance of the toolbar.

For the gullwing hydraulic layout, see "Gullwing Hydraulics" on page 5-3.

WARNING

Avoid being struck by the implement. Failure to follow this information could result in death or serious injury. Make sure all personnel are clear of the implement at all times when the implement is in motion.

Be aware of obstructions above, below, and around the implement when in operation or transport.

Leveling the Midwings

When row units are added to the mid and outer wings, the additional weight may cause the wings to no longer be level with the center section. Check the levelness of the wings over the life of the toolbar to ensure proper performance.

Before adjusting the midwings, inspect implement for damaged or broken parts. Remove any buildup of grease, oil, or debris.

NOTE: Left side midwing leveling procedure is shown. Right side midwing leveling procedure is similar.

| Tools |
|---------------------------|
| • 3-1/8 in Wrench |
| • 9/16 in Wrench (2 used) |
| • 3/4 in Wrench |
| • Level or angle finder |

1. Install the float link lock pin (1) into the float link rigid position to lock the wing in the rigid position. The gullwing hydraulic cylinder (2) must be partially extended to align pin holes in the wing float link plates (3). Lower the machine to enable the gull wing hydraulic cylinders to lower the wings down.

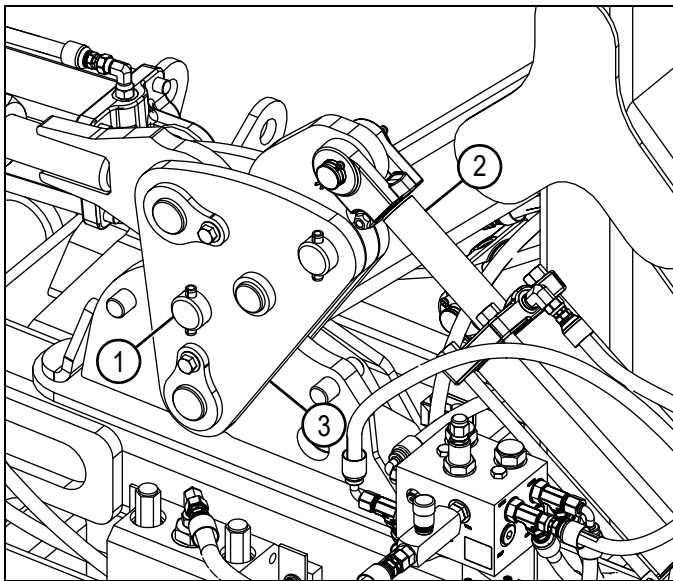

Figure 4-9

ORM000013

- | | |
|--------------------------------|-----------------------------------|
| 1) Float link lock pin | 3) Wing float link plate (2 used) |
| 2) Gullwing hydraulic cylinder | |

2. Park the toolbar on a level surface in the raised position and check the levelness of the rear toolbar center section. This will be the reference point for leveling the midwing.

NOTE: For the greatest accuracy, the wing row units should have all attachments and be fully loaded during leveling.

3. Place the level or angle-finder (4) on the top of the rear frame (5) of the midwing (6) and note its levelness. Compare that levelness to the reference taken from the center section (7). The wing must be from 0° to +2° of level with the center section for proper toolbar function. If the wing angle is lower than or more than 2° of the center section, adjust it using the following steps 4—13.

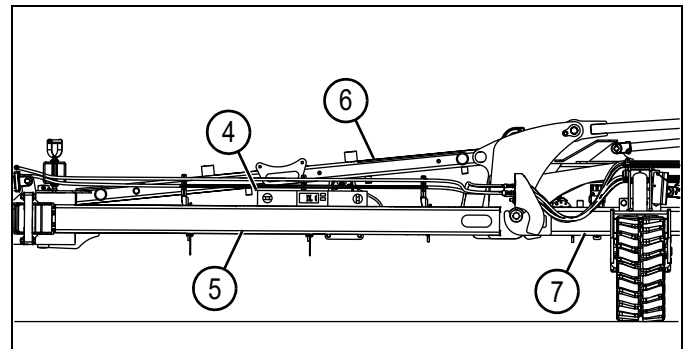

Figure 4-10

ORM000016

- | | |
|-----------------|-------------------|
| 4) Angle-finder | 6) Midwing |
| 5) Rear frame | 7) Center section |

⚠ DANGER

Avoid crushing. Failure to follow this information will result in death or serious injury. Use appropriate stands to support the implement.

4. Support the midwing (9) with a minimum 5-ton stand (8) and lower machine.

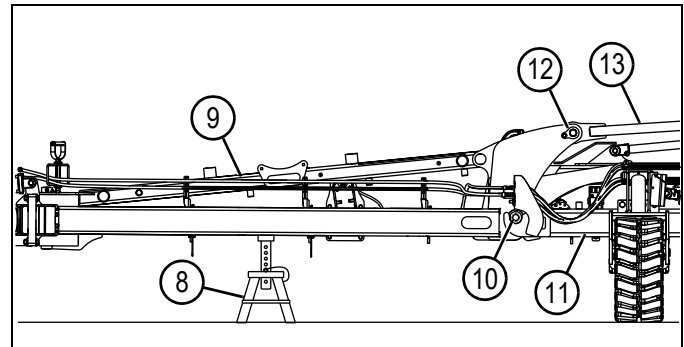

Figure 4-11

ORM000017

- | | |
|-----------------|-----------------------|
| 8) Stand | 11) Center section |
| 9) Midwing | 12) Strut fixed point |
| 10) Pivot point | 13) Strut |

5. Loosen the bolt (14) and nut (15) that tighten the split jam nut (16).
6. Loosen the split jam nut.
7. Remove strut pin (17) and centering pin (18), and disconnect the strut (19) from the float links (20).

NOTE: The gullwing cylinder (21) can be manipulated to reduce the tension on the pins and make it easier during removal.

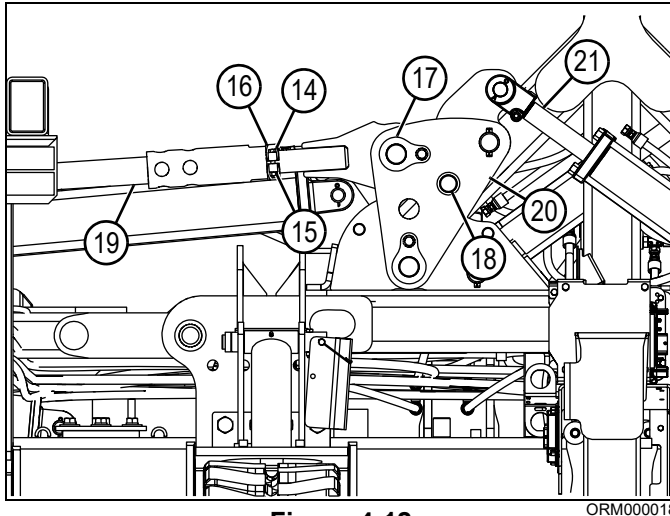

Figure 4-12

ORM000018

- | | |
|-------------------|-------------------------|
| 14) Bolt | 18) Centering pin |
| 15) Nut | 19) Strut |
| 16) Split jam nut | 20) Float link (2 used) |
| 17) Strut pin | 21) Gullwing cylinder |

8. With the strut (22) disconnected from the float links, screw the threaded end (23) clockwise to raise the wing or counterclockwise to lower the wing. Each full turn of the strut end results in approximately a 0.5° change to the wing. Use the previously noted levelness measurements to make the adjustments.

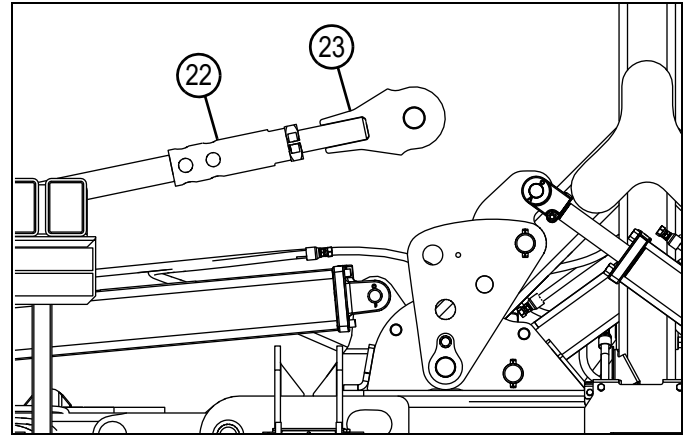

Figure 4-13

ORM000019

- | | |
|-----------|------------------|
| 22) Strut | 23) Threaded end |
|-----------|------------------|

9. Install strut pin and centering pin, and connect the strut to the float links.

NOTE: The gullwing cylinder can be manipulated to reduce the tension on the pins and make it easier during installation.

10. Raise the machine and check the levelness of the wing compared to the center section.
11. If the midwing angle is still lower than or more than 2° of the center section, repeat leveling procedure.
12. If the midwing is within the levelness range, tighten the split jam nut.
13. Tighten the bolt and nut that tighten the split jam nut.

Fold Control Manifold

The 1975 Toolbar is equipped with a manifold for controlling the toolbar fold from one selective control valve (SCV). The manifold automatically sequences the outer wings and stack fold. A flow divider keeps the stacking wings balanced when folding.

The fold control manifold (1) contains components that regulate oil flow in order to control the toolbar. Two counterbalance valves (2) regulate the motion of the wings when they fold over center. Two sequence valves (3) control the timing of the outer wings and stack fold. You can adjust the valves in order to change the fold performance of the toolbar. See "Adjusting the Fold Control Manifold" on page 4-12.

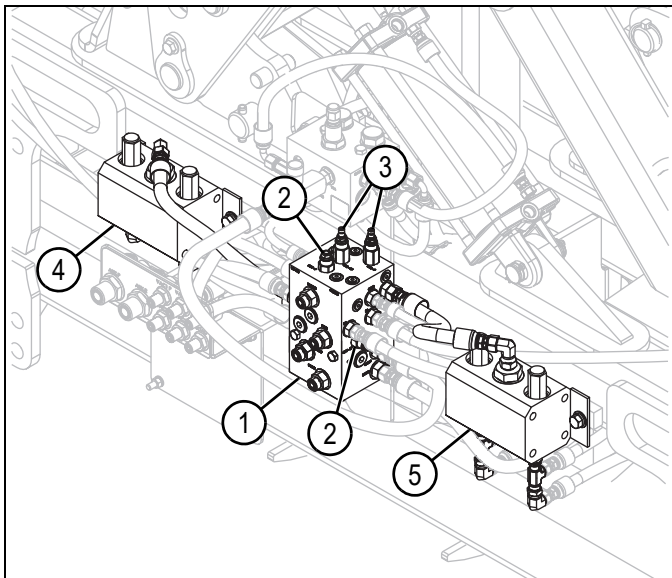

Figure 4-14

ORM000020

- | | |
|-------------------------------------|----------------------------|
| 1) Fold control manifold | 4) Lift wheel flow divider |
| 2) Counterbalance valve (2 used) | 5) Stack cylinder divider |
| 3) Sequence valve (2 used) | |

Manifold Connections

Front Side of Manifold

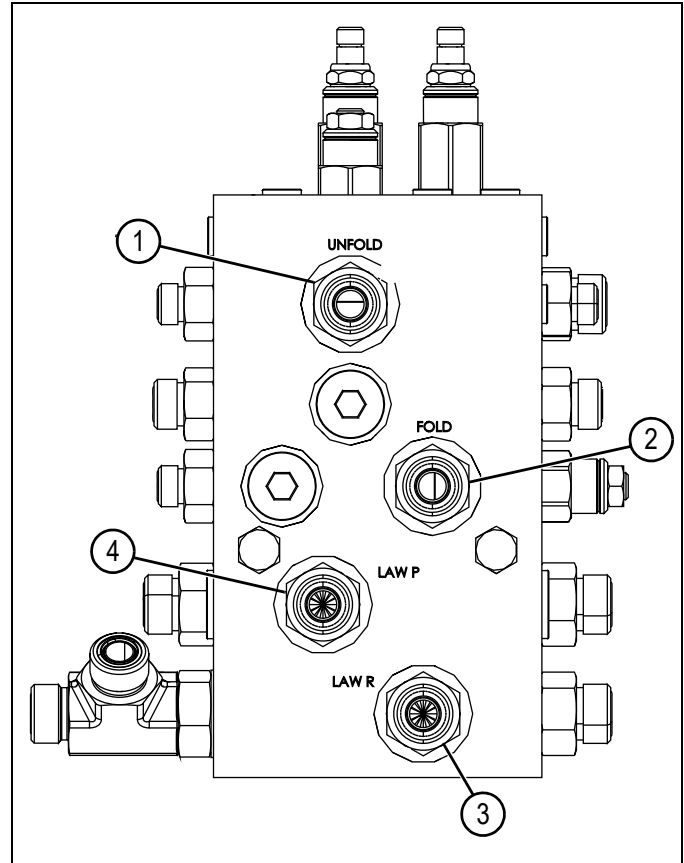

Figure 4-15

ORM000021

- 1) Unfold supply hose from tractor (UNFOLD)
- 2) Fold supply hose from tractor (FOLD)
- 3) Lift wheel return hose (LAW R)
- 4) Lift wheel supply hose (LAW P)

Right Side of Manifold

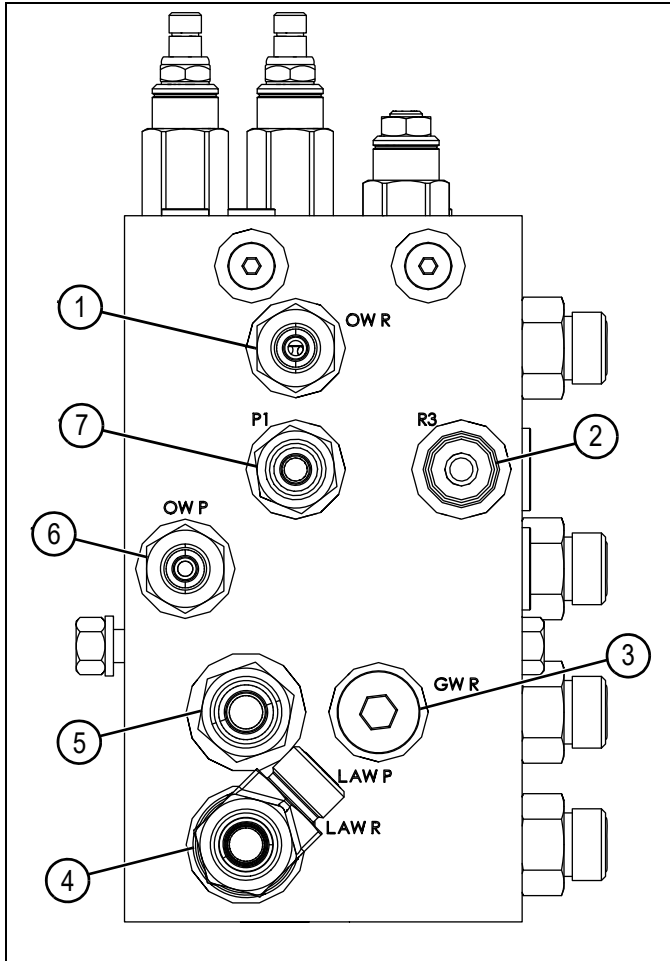

Figure 4-16

ORM00022

- 1) Outer wing return hose (OW R)
- 2) Right secondary stack cylinder rod or plug (R3)
- 3) Gullwing cylinder rod end (GW R)
- 4) Lift wheel cylinders return hose (LAW R)
- 5) Flow divider input hose (LAW P)
- 6) Outer wing pressure hose (OW P)
- 7) Right main stack cylinder base end (P1)

Left Side of Manifold

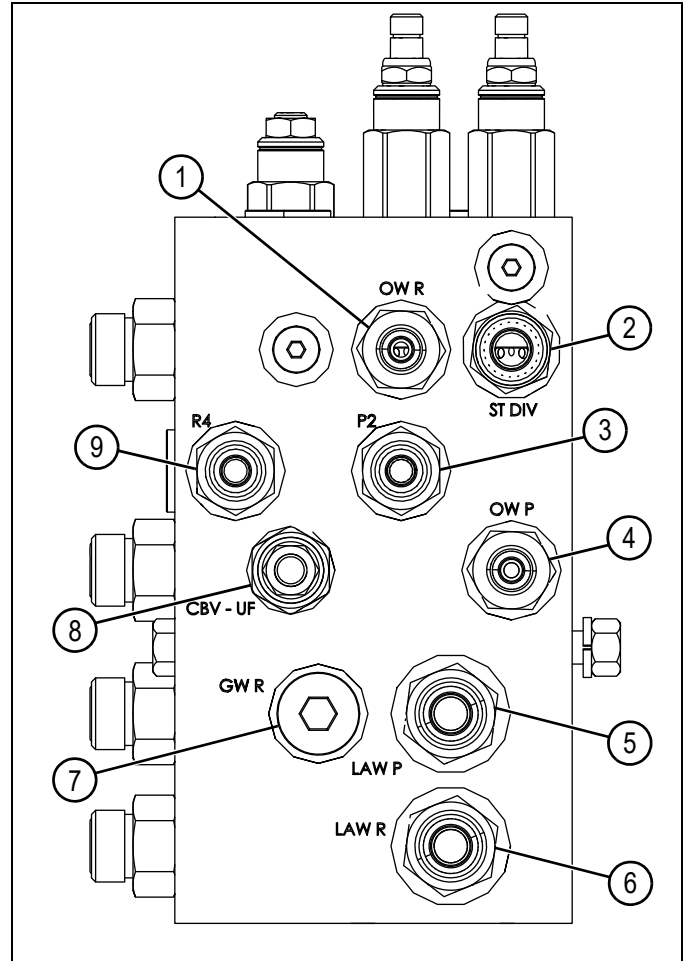

Figure 4-17

ORM00023

- 1) Outer wing return hose (OW R)
- 2) Gear divider input hose (ST DIV)
- 3) Left main stack cylinder base end (P2)
- 4) Outer wing pressure hose (OW P)
- 5) Plug (LAW P)
- 6) Lift wheel cylinders return hose (LAW R)
- 7) Gullwing cylinder rod end (GW R)
- 8) Counterbalance valve (CBV-UF)
- 9) Left secondary stack cylinder rod end or plug (R4)

Adjusting the Fold Control Manifold

For the best results, make sure that the wing row units have all attachments and are fully loaded when you adjust the valves. Before adjusting the fold control manifold, inspect implement for damaged or broken parts. Remove any buildup of grease, oil, or debris.

It is recommended that you adjust the counterbalance valves first. The counterbalance valves restrain the motion of the wings by regulating the flow of oil out of the cylinders. Positive-pressure oil inflow is required in order for the wings to move.

Adjust the Counterbalance Valves

1. Loosen the jam nut (1).
2. Adjust the set screw (2). Counterclockwise adjustment of the counterbalance valve increases the pressure required for oil flow and clockwise adjustment reduces the required pressure.
 - The counterbalance valve (3) labeled “CBV – F” controls the fold sequence. If the outer wings move too quickly when you fold past the center or the stacking wings fall on to the rests too rapidly, adjust the “CBV – F” set screw counterclockwise in one-quarter turn increments until you reach satisfactory fold motion.
 - The counterbalance valve (4) labeled “CBV – UF” controls the unfold sequence. If the un-stacking wings move down too quickly, adjust the “CBV – UF” set screw counterclockwise in one-quarter turn increments until you achieve satisfactory fold motion.

NOTE: Be very careful adjusting the valves; as the full adjustment range is three full turns of the set screw.

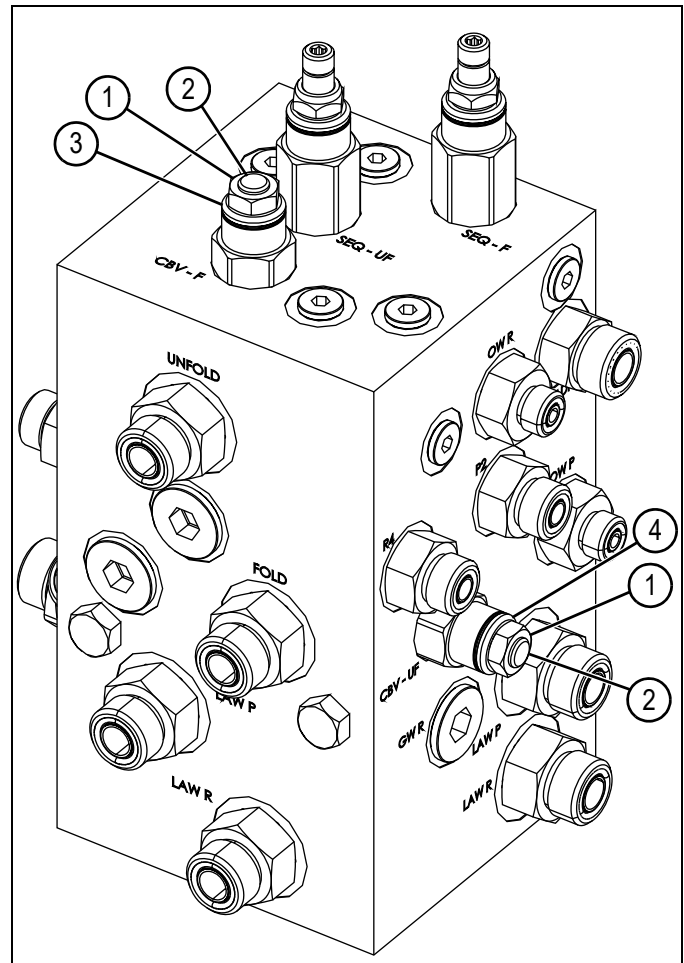

Figure 4-18

ORM000024

- | | |
|-----------------------|-------------------------|
| 1) Jam nut (2 used) | 3) Counterbalance valve |
| 2) Set screw (2 used) | 4) Counterbalance valve |

Adjust the Sequence Valves

To alter the fold timing, adjust the sequence valves (3 and 4).

1. Loosen the jam nut (1).
2. Adjust the set screw (2). Clockwise adjustment of the sequence valve increases the delay between fold functions and counterclockwise adjustment reduces the delay.
 - The sequence valve (3) labeled “SEQ – F” controls the fold sequence. If the wings start to stack before the outer wings are fully folded, then adjust “SEQ – F” set screw clockwise in one-quarter turn increments in order to increase the delay between functions.
 - The sequence valve (4) labeled “SEQ – UF” controls the unfold sequence. If the outer wings start to unfold before the stacking wings are fully down, then adjust “SEQ – UF” set screw clockwise in one-quarter turn increments in order to increase the delay.

NOTE: Use caution when you adjust the valves; as a small turn can have a significant effect.

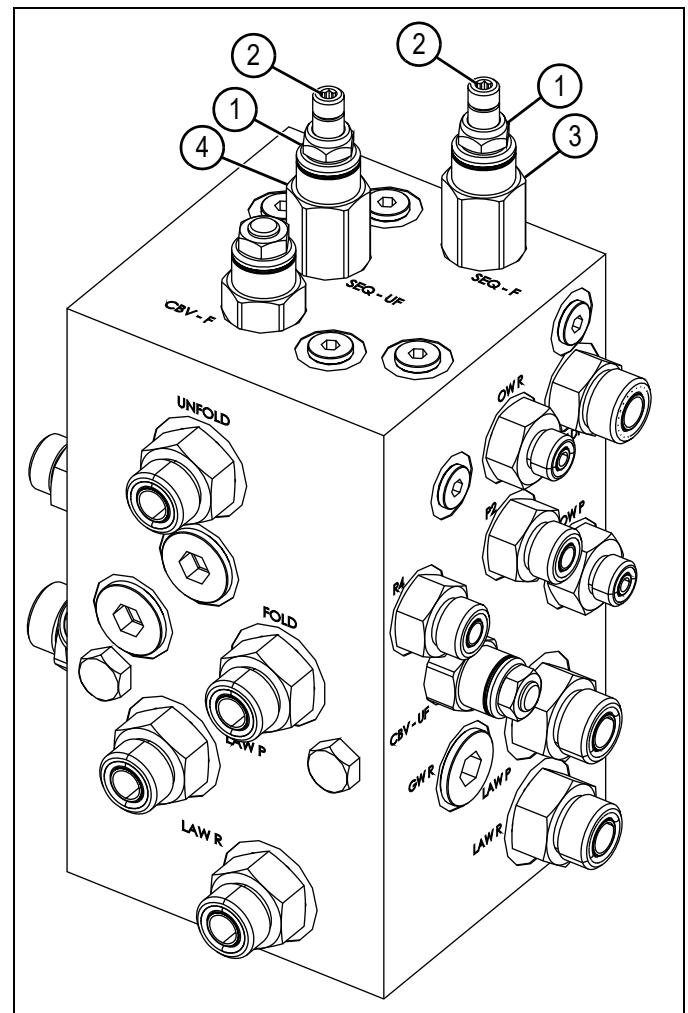

Figure 4-19

ORM000024

- | | |
|-----------------------|-------------------|
| 1) Jam nut (2 used) | 3) Sequence valve |
| 2) Set screw (2 used) | 4) Sequence valve |

Implement Guidance

The 1975 Toolbar is equipped with hardpoints (1) on the center section (2) for mounting the Orthman Tracker IV Implement Guidance system. Mount arms attach to the hardpoints. The mount arms are designed to bridge over the lift wheels (3) and provide depth adjustment for the implement guidance system.

NOTES:

- *The toolbar does not accommodate mechanical row markers.*
- *The implement guidance systems are not compatible with the lift track option.*

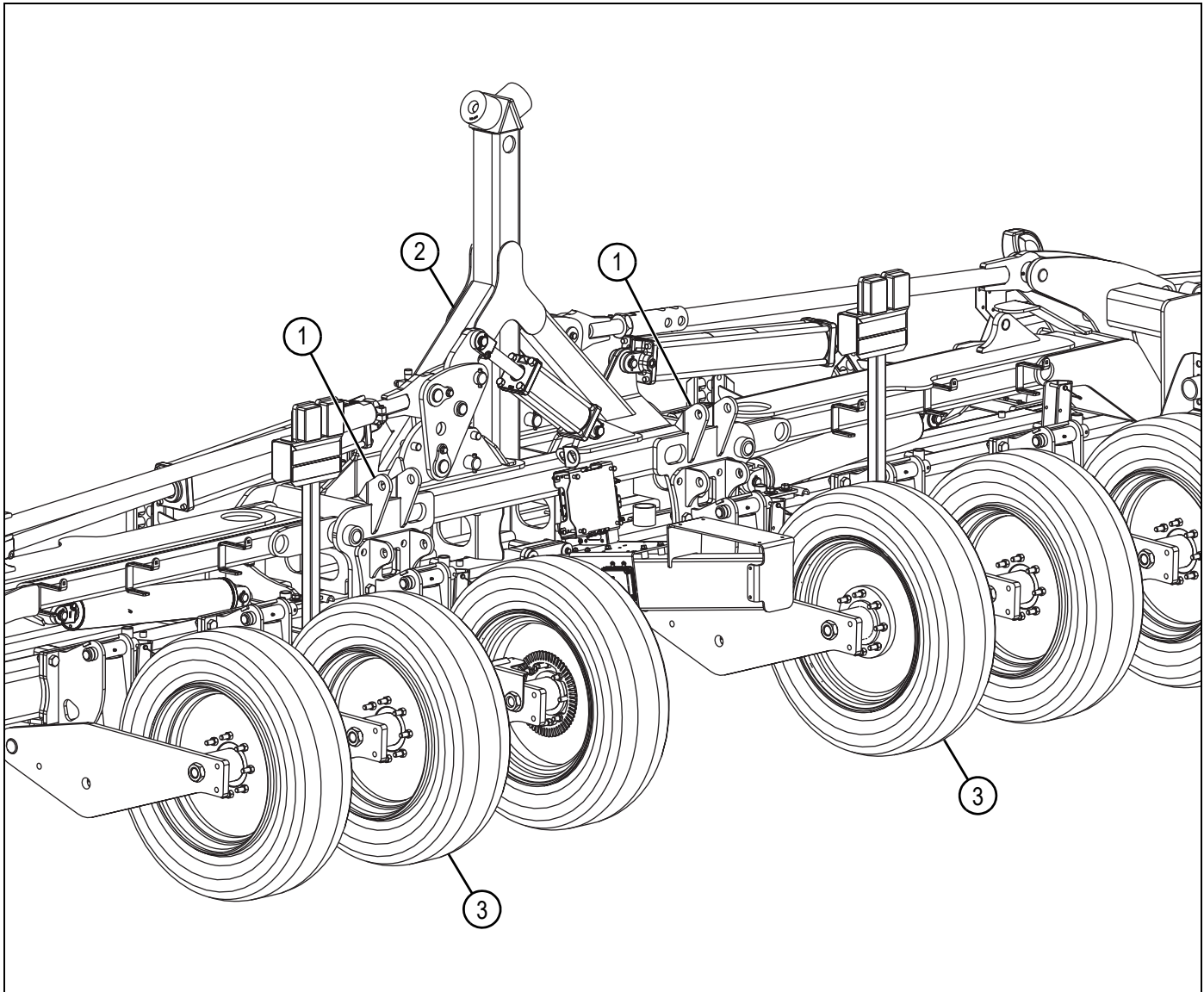

Figure 4-20

ORM00025

1) Hardpoint (2 used)

2) Center section

3) Lift wheel (6 used)

Chapter 5

Operation and Field Settings

| | |
|---|-----|
| Gullwing Feature and Toolbar Float | 5-2 |
| Float and Gullwing Linkage Component Identification | 5-2 |
| Gullwing Hydraulics | 5-3 |
| Hydraulic Bulkhead Connections | 5-4 |
| Toolbar Flex | 5-5 |
| Gullwing Up/Gullwing Down Force Contour | 5-6 |
| Toolbar Height and Orientation | 5-7 |
| Raised Position | 5-7 |
| Field Position | 5-8 |

Gullwing Feature and Toolbar Float

The gullwing kit is standard equipment on the 1975 Toolbar. The gullwing kit provides flexibility to the midwings of the toolbar for covering uneven field terrain. The toolbar flexes in five sections: a rigid center section, right midwing and outer wing, and left midwing and outer wing. The gullwings allow the toolbar midwings to flex up or down approximately 8°.

When the machine is raised at the end of the field, the gullwing hydraulic cylinders retract to “gull” the wings up to provide adequate toolbar clearance when turning around. When the machine is lowered, the toolbar wings will “settle” back to the ground surface, which is accomplished by placing the tractor selective control valve (SCV) remote controlling the machine lift function in “float”, or by placing the tractor SCV remote in “continuous mode” to apply gullwing down force during field operation. Set tractor to the recommended full flow setting and adjust as needed. See the tractor operator’s manual for more information.

CAUTION

Avoid implement damage. Remove the float link pins from the fixed position.

The 1975 Toolbar ships with the wings pinned in the rigid position. Remove the float link pin and place it in the storage position before field operation.

Float and Gullwing Linkage Component Identification

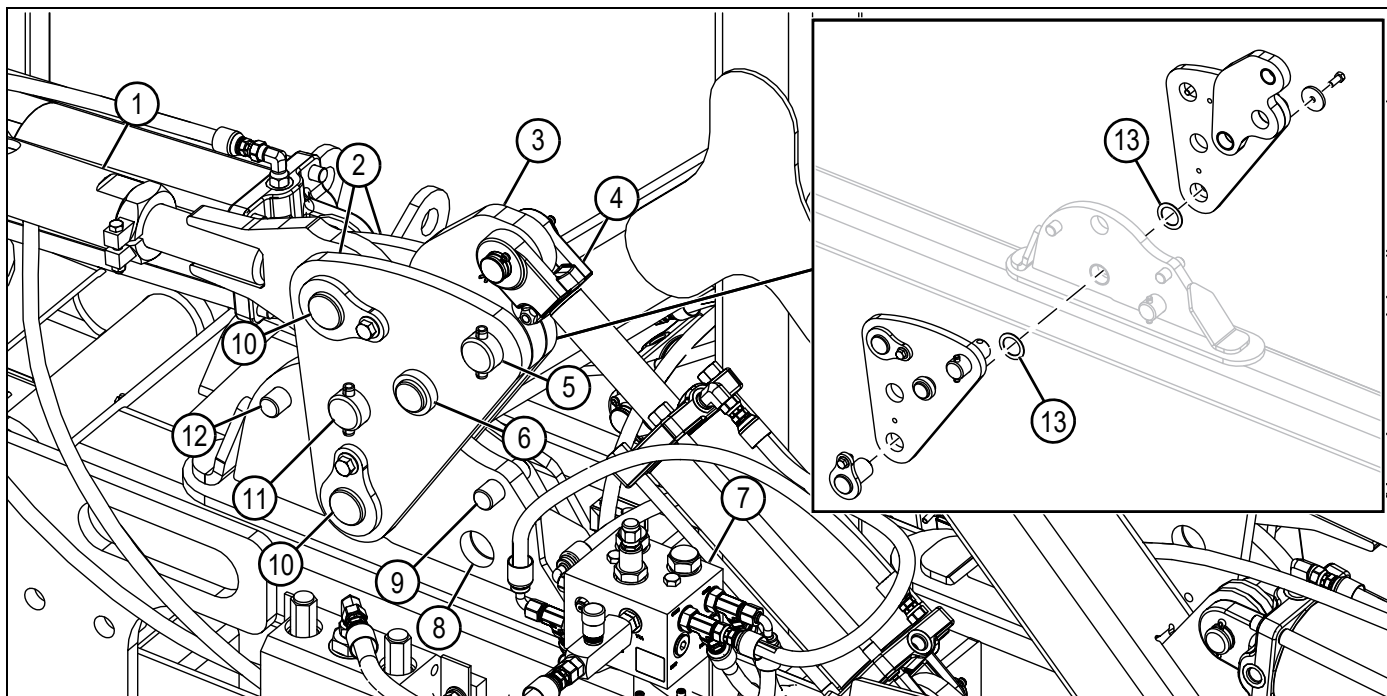

Figure 5-1: Right Gullwing Kit

ORM000045

- | | | |
|-----------------------------------|---|-------------------------------|
| 1) Strut | 6) Centering pin | 10) Pin (2 used) |
| 2) Wing float link plate (2 used) | 7) Gullwing manifold | 11) Float link rigid position |
| 3) Gullwing link plate | 8) Float link lock pin storage position | 12) Wing down stop |
| 4) Gullwing cylinder | 9) Wing up stop | 13) Washer (2 used) |
| 5) Gullwing pin position | | |

Gullwing Hydraulics

The gullwing cylinders (1) are connected to the same circuit as the outer wing up/down cylinders (2) for simultaneous operation. The gullwing cylinders and outer wing up/down cylinders are controlled by the gullwing manifold (3). The gullwing manifold connects to the fold control manifold (5).

The rod end of the left gullwing and outer wing up/down cylinders connect to the return side of the gullwing manifold at the port labeled GWR2. The rod end of the right gullwing and outer wing up/down cylinders connect to the return side of the gullwing manifold at the port labeled GWR1.

The base end of the left gullwing and outer wing up/down cylinders connect to the supply side of the gullwing manifold at the port labeled GWP2. The base end of the right gullwing and outer wing up/down cylinders connect to the supply side of the gullwing manifold at the port labeled GWP1.

The gullwing manifold port labeled V1A connects to the left side of the fold control manifold at the port labeled LAW P. The gullwing manifold port labeled V1B connects to the right side of the fold control manifold at the port labeled LAW R.

Place the outer wing and gullwing hydraulics in float during field operation. This ensures the proper performance of the toolbar.

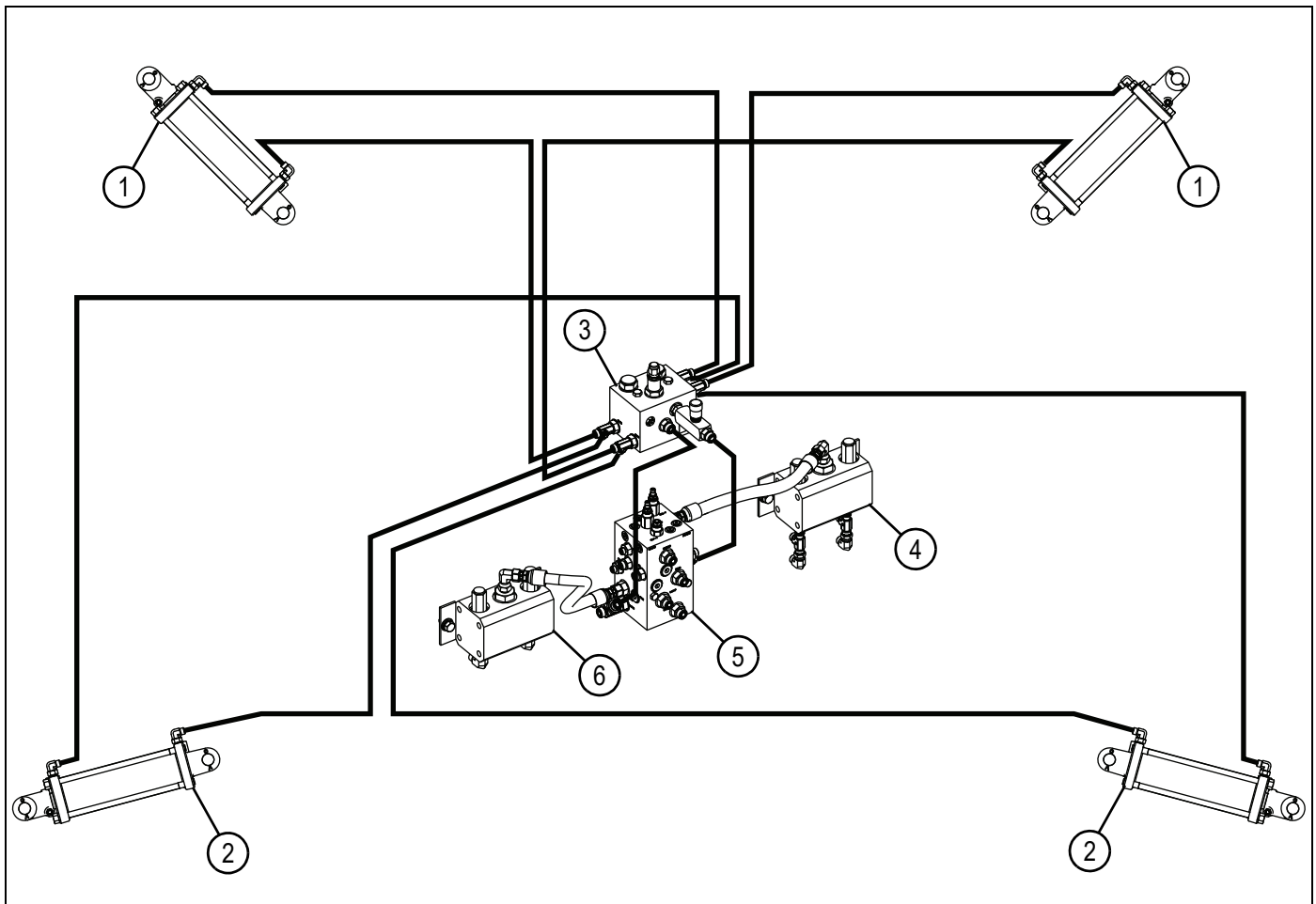

Figure 5-2

ORM000029

- | | | |
|---|---------------------------|----------------------------|
| 1) Gullwing cylinder (2 used) | 3) Gullwing manifold | 5) Fold control manifold |
| 2) Outer wing up/down cylinder (2 used) | 4) Stack cylinder divider | 6) Lift wheel flow divider |

Hydraulic Bulkhead Connections

The toolbar is equipped with a labeled hydraulic bulkhead plate located on the implement tongue. For hydraulic bulkhead location, see “Central Commodity System (CCS) Planter Tongue and Hitch” on page 3-7. The hydraulic bulkhead (1) connects the toolbar hydraulics to the tractor hydraulic system.

To fold and unfold the wings, the fold control manifold connects to the hydraulic bulkhead. The fold pressure hose connects to the bulkhead at the port labeled FOLD P (4). The fold return hose connects to the bulkhead at the port labeled FOLD R (5).

To raise and lower the lift wheel/track, the fold control manifold connects to the hydraulic. The lift assist wheel return hose connects to the bulkhead at the port labeled LAW R (2). The lift assist wheel pressure hose connects to the bulkhead at the port labeled LAW P (3).

For more information on fold control manifold connections, see “Fold Control Manifold” on page 4-10.

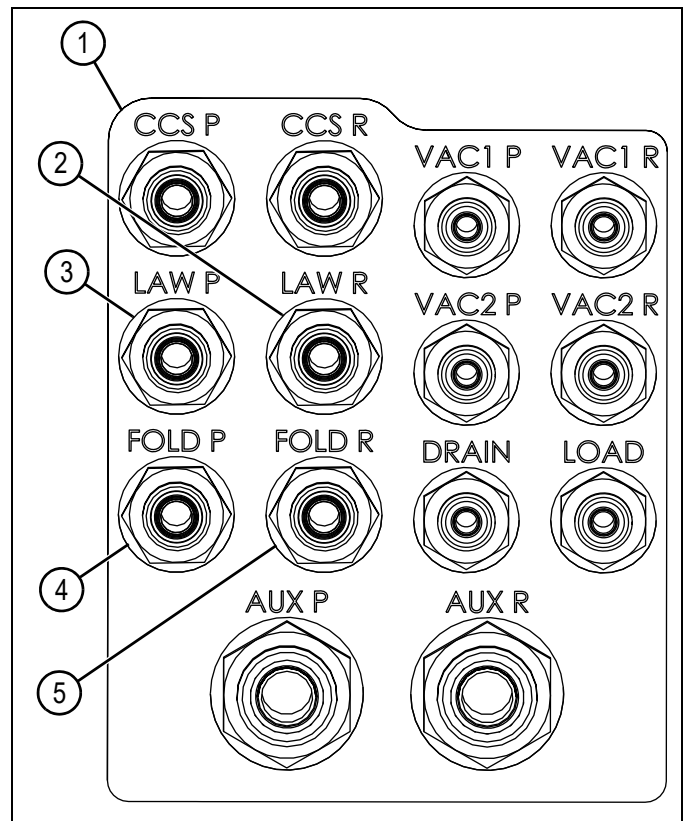

Figure 5-3

ORM000044

- 1) Hydraulic bulkhead
- 2) Lift assist wheel return (LAW R)
- 3) Lift assist wheel pressure (LAW P)
- 4) Fold pressure (FOLD P)
- 5) Fold return (FOLD R)

Toolbar Flex

When in the field position, the toolbar flexes in five sections with the midwing and outer wings (1 and 2) able to flex $\pm 8^\circ$ individually, allowing $\pm 16^\circ$ of total flex on each wing.

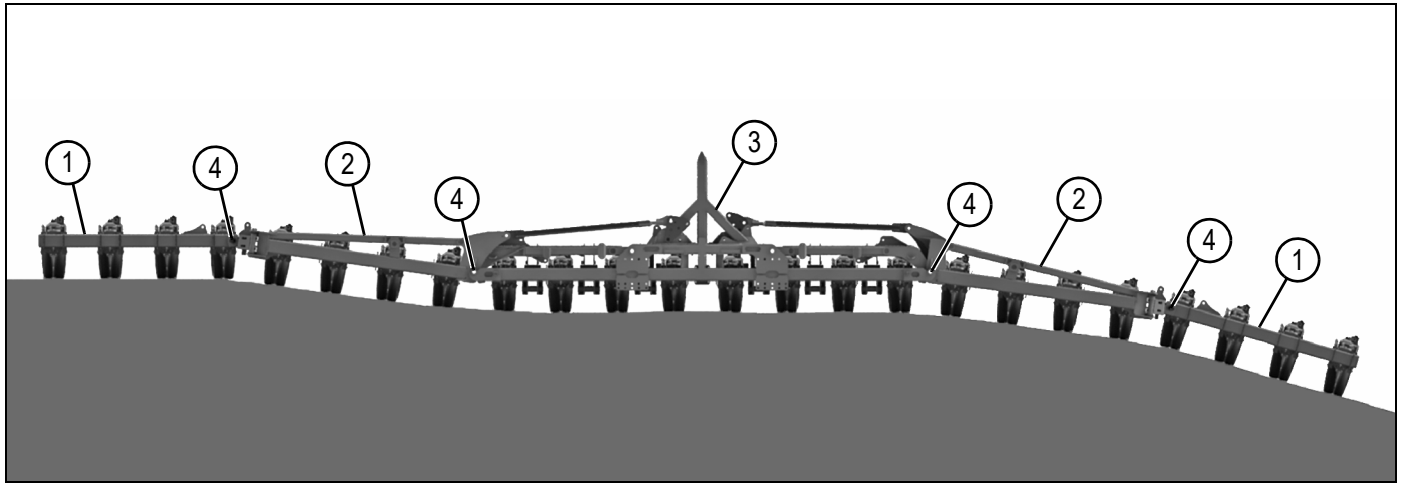

Figure 5-4

ORM000031

- 1) Outer wing (2 used) 2) Midwing (2 used) 3) Center section 4) Pivot point (4 used)

CAUTION

Avoid implement damage. Remove the float link lock pins (5) from the fixed position.

To allow for toolbar flex, remove the float link lock pins (5) from the rigid position and place in the float link lock pin storage positions (6).

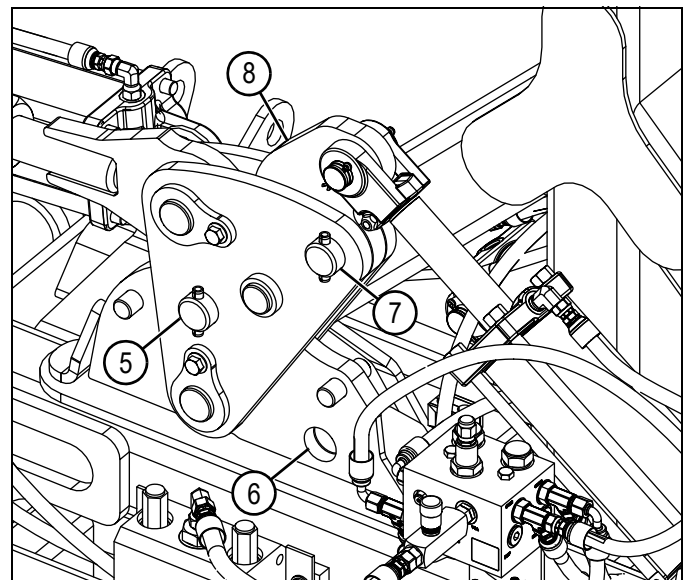

Figure 5-5: Right Gullwing

ORM000013

- 5) Float link lock pin (2 used) 7) Gullwing pin (2 used)
 6) Float link lock pin storage position (2 used) 8) Gullwing (2 used)

Gullwing Up/Gullwing Down Force Contour

⚠WARNING

Avoid being struck by the implement. Failure to follow this information could result in death or serious injury. Make sure all personnel are clear of the implement at all times when the implement is in motion.

When the implement is raised at the end of the field, the wings “gull up.” While the implement is in the field position, the toolbar is allowed to “float” or apply gullwing down force.

When the tractor selective control valve (SCV) remote controlling the machine lift function is placed in “float” and the machine is lowered at the end of the field, the wings will “settle” back to flat. While the machine is in the field position, the toolbar is allowed to “float” up or down $\pm 16^\circ$ to contour the terrain. When the tractor SCV remote controlling the machine lift function is placed in “continuous mode” at full flow, gullwing down force is applied through the midwing and outer cylinders to keep the row units in the ground depending on field conditions.

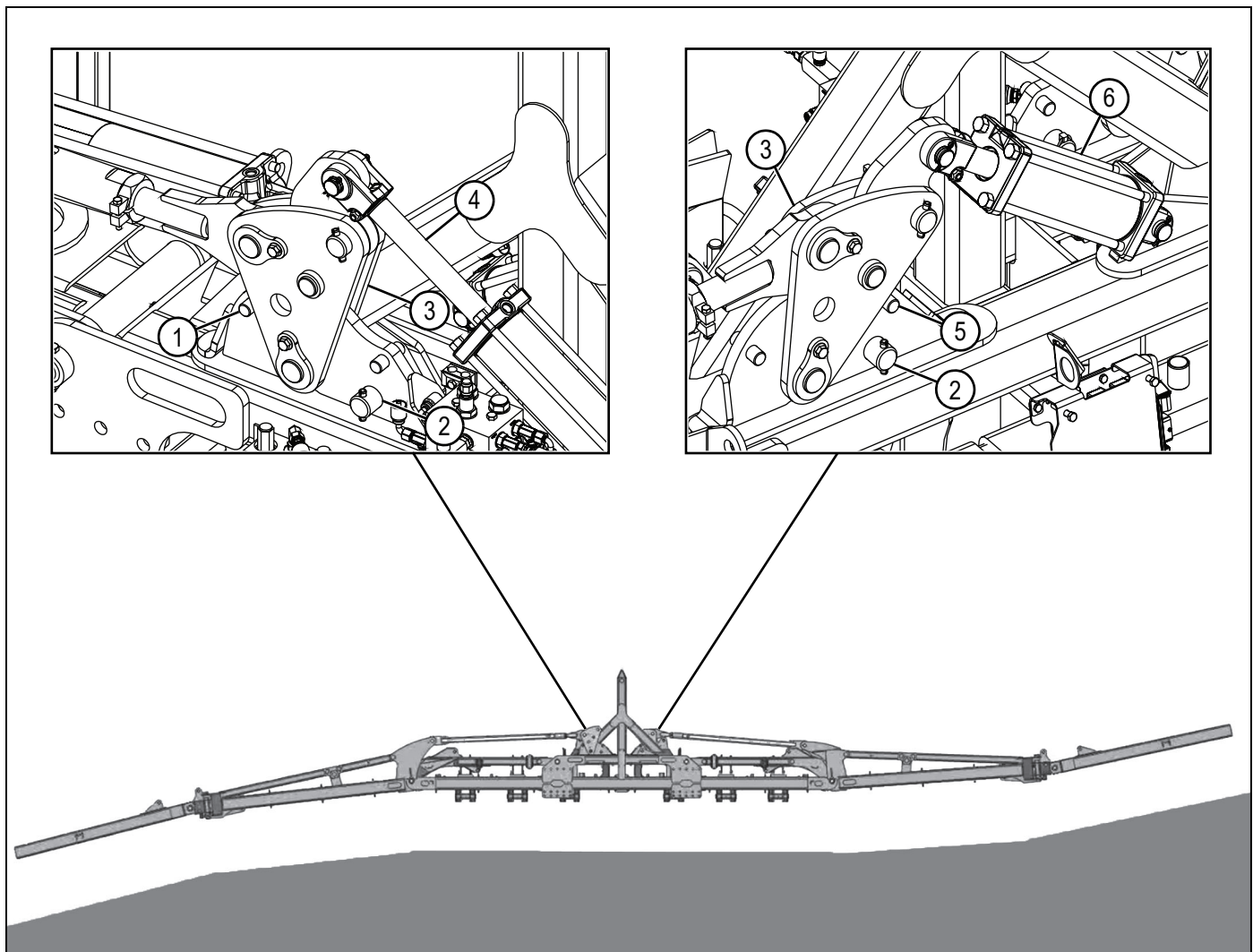

Figure 5-6: Float/Gullwing Down Force Contour

ORM000043

- | | |
|--|----------------------------------|
| 1) Wing down stop | 4) Gullwing cylinder (extended) |
| 2) Float link lock pin storage position (2 used) | 5) Wing up stop |
| 3) Gullwing (2 used) | 6) Gullwing cylinder (retracted) |

Toolbar Height and Orientation

The 1975 Toolbar is semi-mounted with a knuckle hitch. The lift wheels/tracks on the center section also serve as the center section gauge wheels. The lift wheels/tracks operate from a selective control valve (SCV) on the tractor. See the tractor operator's manual for more information on operating the SCV.

Raised Position

1. Connect the implement hitch (1) to the tractor. See "Implement-to-Tractor Connection" on page 4-3.
2. Raise the tractor three-point hitch to its highest point.
3. Fully extend the lift wheel/track cylinders (3).

⚠ DANGER

Avoid crushing. Failure to follow this information will result in death or serious injury. Use bar stands and cylinder stops to support the implement.

4. If transporting or servicing the toolbar, install safety transport locks (4) on the lift wheel/track cylinders.

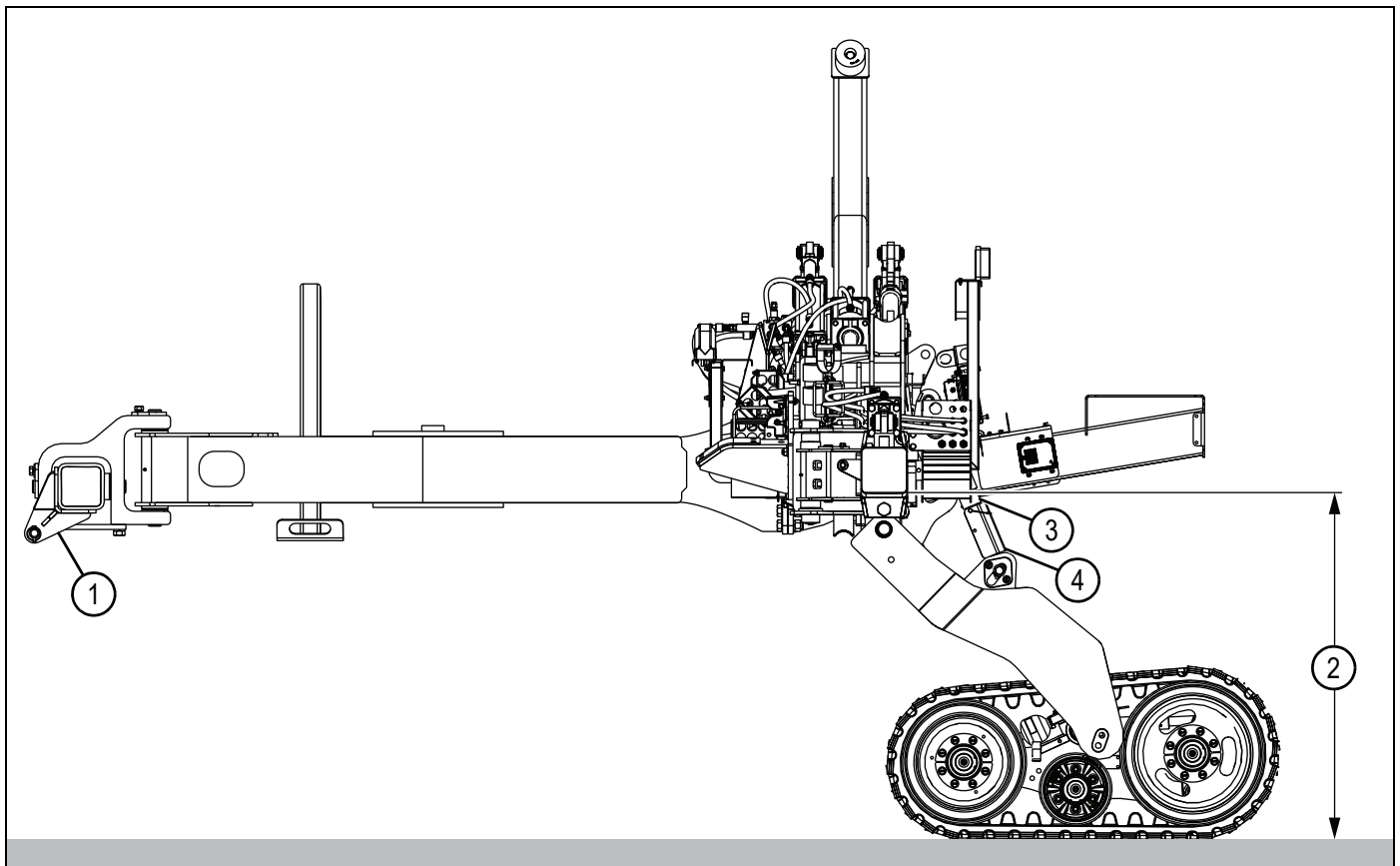

Figure 5-7

ORM000035

- 1) Hitch
- 2) Approximate height 48 in (122 cm)

- 3) Lift wheel/track cylinder (6 used)
- 4) Safety transport lock (4 used)

Field Position

1. Connect the implement hitch (1) to the tractor. See “Implement-to-Tractor Connection” on page 4-3.
2. Set the tractor three-point hitch lowering limit so the tongue and toolbar are parallel with the terrain. See the tractor operator’s manual for more information on adjusting the tractor’s hitch.
3. Fully retract the lift wheel/track cylinders (4). This will provide 20–22 in (52–56 cm) of clearance from the ground surface to the bottom of the toolbar.

NOTE: *Ground conditions vary from field to field and may warrant the use of provided cylinder stops to reduce toolbar lowering depth. These cylinder stops clamp around the rod of each hydraulic lift cylinder.*

4. Place tractor selective control valve (SCV) remote in the “float” position to allow the planter to “float” over the ground surface and ensure consistent operating depth, or place the tractor SCV remote in “continuous mode” to apply down force to the row units depending on field conditions. If desired the wings can be locked in the rigid position during planting by placing the float link in the rigid position.
5. Row unit parallel linkage arms should run parallel with the ground surface. Refer to row unit operator’s manual for setting instructions.
6. Planter gauge wheels on the toolbar wings should be set to operate planter at the proper operating height. Refer to planter operator’s manual for setting instructions.
7. Depending on the particular planter and field conditions, it may be necessary, through a process of trial and error, to manipulate tractor hitch settings, cylinder stops, and planter gauge wheels in order to achieve optimum planter operating height.

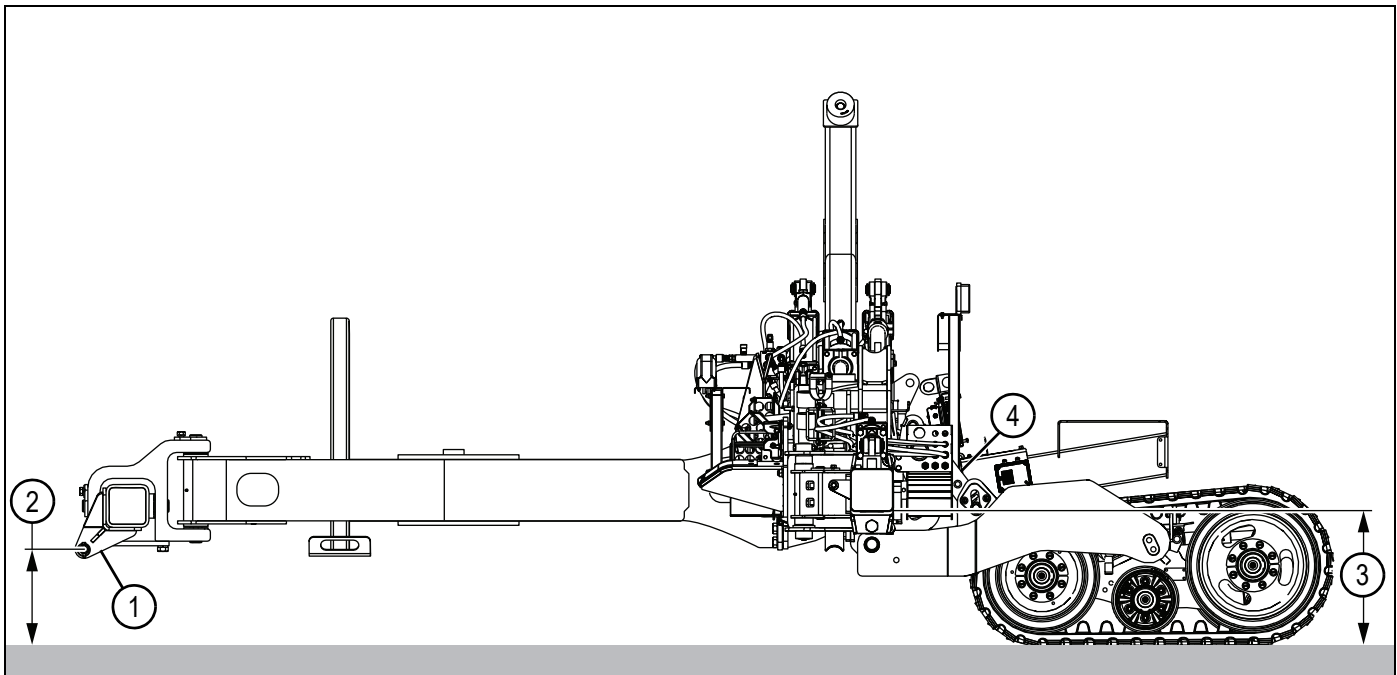

Figure 5-8

ORM000036

- | | |
|---------------------------------------|---|
| 1) Hitch | 3) Approximate height 20–22 in (52–56 cm) |
| 2) Approximate height 16 in (40.5 cm) | 4) Lift wheel/track cylinder (6 used) |

Chapter 6

Troubleshooting

| | |
|--|-----|
| Machine Frame | 6-2 |
| Preventative Measures | 6-2 |
| Troubleshooting | 6-3 |
| Components Showing Premature Wear | 6-3 |
| Toolbar Does Not Operate at the Proper Height | 6-3 |
| Toolbar Does Not Operate Level With the Ground | 6-3 |
| Toolbar Does Not Fold Correctly | 6-3 |
| Toolbar Wings Are Not Level or Straight | 6-3 |
| Hydraulic | 6-4 |
| Preventative Measures | 6-4 |
| Troubleshooting | 6-5 |
| Toolbar Wings Not Stacking Properly | 6-5 |
| Toolbar Outer Wings Not Folding In Before Stacking | 6-5 |
| Toolbar Outer Wings Fold Inward on Their Own During Field Operation | 6-5 |
| Machine Settles to the Ground on Its Own in Parked Position | 6-5 |
| Wings Not Gulling Down When Machine is Lowered | 6-6 |
| Gullwing Down Force is Not Enough to Keep Row Units in the Ground | 6-6 |
| Wings Gull Up When Machine is Placed in Field Position | 6-6 |
| Machine Lowers the Lifting Gauge Wheels Before the Hitch or Raises After the Hitch | 6-6 |
| Toolbar Wings Unstack Too Quickly | 6-6 |

Machine Frame

DANGER

Avoid crushing. Failure to follow this information will result in death or serious injury. Make sure all personnel are clear of the implement before lowering.

Lower the implement to the ground, place the tractor in park, turn off the engine, and remove the key.

DANGER

Avoid crushing. Failure to follow this information will result in death or serious injury. Use bar stands and cylinder stops to support the implement.

Store the implement on a clean, dry, level surface. An uneven surface could cause the implement to shift or fall, resulting in injury or death as well as implement damage. Securely support all implement components that must be raised. Store the implement away from human activity.

Remove buildup of grease, oil, and debris before you adjust the implement.

Preventative Measures

CAUTION

Avoid implement damage. Always perform the following preventative measures.

- Lubrication of all load bearing points.
- All hardware should be checked for tightness before operation.
- Bridging between lifting gauge wheels on semi-mount planters.
- Planter must always have at least four of the lifting gauge wheels bearing the weight of the machine at all times. If bridging occurs, such as when only the two outer lift wheels are supporting the weight of the machine while it is straddling a low point in the field, this causes the mast plates between the lifting wheel hydraulic cylinders to bow out and eventually fail.
- Bridging between tracker implement guidance unit and planter frame on machines equipped with a Tracker IV system.
- The Tracker IV system should never bear any of the weight of the machine. This can happen if the machine crosses an extreme and sudden low point in the field, which may cause the lifting wheels to no longer make contact with the ground, leaving all the weight of the machine on the Tracker IV unit. This causes damage to the connecting arms and mounts of the Tracker IV system.

Troubleshooting

DANGER

High-pressure fluid can penetrate eyes and skin. Relieve pressure on hydraulic system before servicing or disconnecting hoses. Wear proper hand and eye protection. When searching for leaks, use cardboard or wood instead of hands.

Components Showing Premature Wear

- Always check for added, unapproved weight to toolbar, such as extra suitcase weights, fertilizer tanks, aftermarket row unit attachments, etc.
- Check for signs of improper use.
- Check associated lubrication points. Do they appear to have been recently greased?

Toolbar Does Not Operate at the Proper Height

See “Field Position” on page 5-8.

Toolbar Does Not Operate Level With the Ground

The levelness of the toolbar is governed by the settings of the lifting gauge wheels or tracks and the tractor hitch.

First make sure that the lifting gauge wheels or tracks are set for the correct height following procedures in “Field Position” on page 5-8. Then adjust the lower stops on the tractor hitch until the toolbar is level.

Consult the tractor operator’s manual for information on setting the hitch.

Toolbar Does Not Fold Correctly

DANGER

High-pressure fluid can penetrate eyes and skin. Relieve pressure on hydraulic system before servicing or disconnecting hoses. Wear proper hand and eye protection. When searching for leaks, use cardboard or wood instead of hands.

- Check to see if the hydraulic tips are installed incorrectly in the tractor selective control valve (SCV).
- Check to see if the fold control manifold is adjusted correctly. See “Adjusting the Fold Control Manifold” on page 4-12.
- Check to make sure that the wings are level. Adjust wings to level position. See “Leveling the Midwings” on page 4-8.
- Check to see if the cylinder seals are bad.
- Check to see if there is enough tractor hydraulic pressure.

Toolbar Wings Are Not Level or Straight

Adjust wings to the level position. See “Leveling the Midwings” on page 4-8.

Hydraulic

DANGER

Avoid crushing. Failure to follow this information will result in death or serious injury. Make sure all personnel are clear of the implement before lowering.

Lower the implement to the ground, place the tractor in park, turn off the engine, and remove the key.

DANGER

Avoid crushing. Failure to follow this information will result in death or serious injury. Use bar stands and cylinder stops to support the implement.

Store the implement on a clean, dry, level surface. An uneven surface could cause the implement to shift or fall, resulting in injury or death as well as implement damage. Securely support all implement components that must be raised. Store the implement away from human activity.

Remove buildup of grease, oil, and debris before you adjust the implement.

Preventative Measures

CAUTION

Avoid hydraulic system damage. Always perform the following preventative measures.

- Be sure all hydraulic hoses are securely connected and all fittings are tight.
- Be sure all hydraulic hoses are secured in a manner that keeps them away from sharp edges and moving objects that can rupture a hose.
- Be sure the case drain hose connected to all hydraulic motors of the machine (such as the vacuum fans and/or the central commodity system [CCS] blower fan) is connected to the case drain port of the tractor.
- The case drain allows hydraulic oil to flow out of the motor casing and back into the tractor sump when hydraulic fluid is no longer being sent to the motor. If this fluid was not able to escape the motor casing, damage may occur to the internal components of the hydraulic motor if the motor is stopped suddenly and not allowed to slow down gradually. As a good practice, the tractor selective control valve (SCV) controlling the hydraulic motor should always be placed in "float" when the hydraulic motor is intended to be stopped.
- Be sure the tractor hydraulic system has the proper amount of hydraulic fluid.

Troubleshooting

DANGER

High-pressure fluid can penetrate eyes and skin. Relieve pressure on hydraulic system before servicing or disconnecting hoses. Wear proper hand and eye protection. When searching for leaks, use cardboard or wood instead of hands.

Toolbar Wings Not Stacking Properly

- Check for leakage at the gear flow divider.
- Check for leakage at the stacking cylinders.
- Check that all hydraulic hoses are connected properly.
- Check for deformation in the wing strut. Deformation may cause folding geometry issues.
- Check for deformation in the wing pins. Deformation may cause folding geometry issues.
- Gear flow divider could be faulty.

Toolbar Outer Wings Not Folding In Before Stacking

Toolbar outer wings unfolding out before unstacking (dual fold planters only).

Sequencing valve needs adjustment. See “Adjust the Sequence Valves” on page 4-13.

Toolbar Outer Wings Fold Inward on Their Own During Field Operation

Fitting not tightened/hydraulic cylinder seals failed.

- In this instance, oil would be visibly leaking out of the system.
- Tighten all fittings and replace cylinder seals as needed.

Air may be in the circuit.

- Purge the air out by cycling the fold and unfold sequences continuously and holding the tractor selective control valve (SCV) lever down for about 15 seconds after the hydraulic cylinders are fully stroked.

Oil may be leaking out of the circuit through the counterbalance valves.

- Replace the counterbalance valve cartridges on the toolbar hydraulic manifold block.

Toolbar hydraulic manifold block may be cracked internally.

- This would cause oil to leak out of the circuit and into other circuits within the toolbar manifold block.
- Replace manifold block.

Machine Settles to the Ground on Its Own in Parked Position

Fitting not tightened/hydraulic cylinder seals failed.

- In this instance, oil would be visibly leaking out of the system.
- Tighten all fittings and replace cylinder seals as needed.

Air may be in the circuit.

- Purge the air out by cycling the lift and lower sequences continuously and holding the tractor selective control valve (SCV) lever down for about 15 seconds after the hydraulic cylinders are fully stroked.

Toolbar hydraulic manifold block may be cracked internally.

- This would cause oil to leak out of the circuit and into other circuits within the toolbar manifold block.
- Replace manifold block.

Wings Not Gulling Down When Machine is Lowered

Make sure flow control valve from gulling manifold block is properly set. If valve is completely closed off, gulling will not come down. The corresponding graph shows flow rates for the colored sections from 0–15 GPM. Recommended to start at setting "blue" or 6 GPM and adjust accordingly.

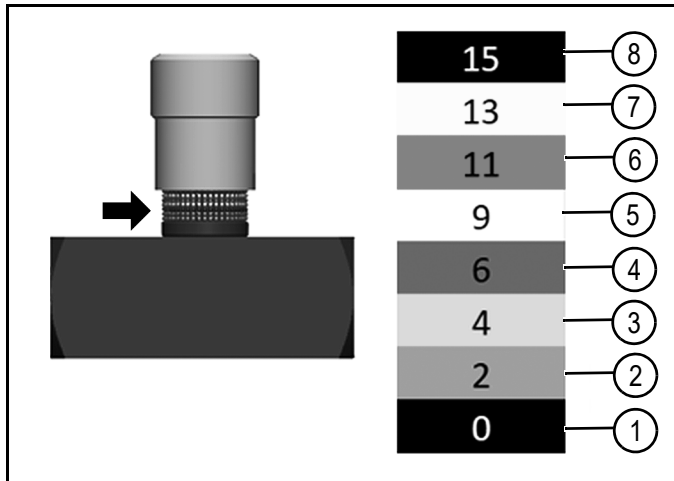

Figure 6-1

ORM000038

- | | |
|-----------------|------------------|
| 1) 0 GPM black | 5) 9 GPM white |
| 2) 2 GPM green | 6) 11 GPM red |
| 3) 4 GPM orange | 7) 13 GPM yellow |
| 4) 6 GPM blue | 8) 15 GPM black |

Be sure operator is placing the tractor selective control valve (SCV), that controls the raise and lower functions, in "float" when lowering the planter to field position.

Keep in mind that the planter toolbar does not typically fully gull down before planter center section makes contact with the ground surface.

Be sure breather fittings on gulling hydraulic cylinder base ends are not clogged or obstructed.

Gulling Down Force is Not Enough to Keep Row Units in the Ground

Recommended to set gulling selective control valve (SCV) to "continuous" level 10, ensuring full flow to the gulling down force. Adjust accordingly to field conditions.

There is a chance that field conditions warrant more pressure to your gulling down force. Contact your local dealer for adjustment if needed.

Wings Gull Up When Machine is Placed in Field Position

Be sure hydraulic hoses are connected correctly.

Machine Lowers the Lifting Gauge Wheels Before the Hitch or Raises After the Hitch

Check to see if planter lift hydraulic hoses are plumbed into the tractor three-point "rock shaft".

- This is not recommended; as it causes timing issues.
- Different tractor manufacturers require a special kit to be installed that disables the hitch control lever and allows for both hitch and lift wheel control with one selective control valve (SCV). Contact tractor dealer for a special kit.

Toolbar Wings Unstack Too Quickly

Toolbar wings fold past center and crash into wing rests.

Counterbalance valve needs to be adjusted.

Chapter 7

Maintenance

| | |
|---|-----|
| Practice Safe Maintenance | 7-2 |
| Torque Specifications | 7-2 |
| Lubrication | 7-3 |
| Hitch Grease Locations | 7-3 |
| Lift Wheel/Track Grease Locations | 7-3 |
| Outer Wing Grease Locations | 7-4 |
| Midwing Grease Locations | 7-4 |
| Center Grease Locations | 7-4 |
| Implement Inspection | 7-5 |
| Implement Storage | 7-5 |
| Notes | 7-6 |

Practice Safe Maintenance

Proper maintenance is your responsibility. Maintenance neglect and/or poor maintenance practices can result in injury or death. Always use the proper tools to maintain the implement. For more information on practicing safe maintenance, see “Practice Safe Maintenance” on page 2-8.

Torque Specifications

Unified bolt and screw torque values:

| Bolt or Screw Size (inches) | SAE Grade 1 | | | | SAE Grade 2 | | | | SAE Grade 5, 5.1, or 5.2 | | | | SAE Grade 8 or 8.2 | | | |
|-----------------------------|-------------|-------|------|-------|-------------|-------|------|-------|--------------------------|-------|------|-------|--------------------|-------|------|-------|
| | Lubricated | | Dry | | Lubricated | | Dry | | Lubricated | | Dry | | Lubricated | | Dry | |
| | N•m | lb-in | N•m | lb-in | N•m | lb-in | N•m | lb-in | N•m | lb-in | N•m | lb-in | N•m | lb-in | N•m | lb-in |
| 1/4 | 3.7 | 33 | 4.7 | 42 | 6 | 53 | 7.5 | 66 | 9.5 | 84 | 12 | 106 | 13.5 | 120 | 17 | 150 |
| | | | | | | | | | | | | | N•m | lb-ft | N•m | lb-ft |
| 5/16 | 7.7 | 68 | 9.8 | 86 | 12 | 106 | 15.5 | 137 | 19.5 | 172 | 25 | 221 | 28 | 20.5 | 35 | 26 |
| | | | | | | | | | N•m | lb-ft | N•m | lb-ft | | | | |
| 3/8 | 13.5 | 120 | 17.5 | 155 | 22 | 194 | 27 | 240 | 35 | 26 | 44 | 32.5 | 49 | 36 | 63 | 46 |
| | | | N•m | lb-ft | N•m | lb-ft | N•m | lb-ft | | | | | | | | |
| 7/16 | 22 | 194 | 28 | 20.5 | 35 | 26 | 44 | 32.5 | 56 | 41 | 70 | 52 | 80 | 59 | 100 | 74 |
| | N•m | lb-ft | | | | | | | | | | | | | | |
| 1/2 | 34 | 25 | 42 | 31 | 53 | 39 | 67 | 49 | 85 | 63 | 110 | 80 | 120 | 88 | 155 | 115 |
| 9/16 | 48 | 35.5 | 60 | 45 | 76 | 56 | 95 | 70 | 125 | 92 | 155 | 115 | 175 | 130 | 220 | 165 |
| 5/8 | 67 | 49 | 85 | 63 | 105 | 77 | 135 | 100 | 170 | 125 | 215 | 160 | 240 | 175 | 308 | 225 |
| 3/4 | 120 | 88 | 150 | 110 | 190 | 140 | 240 | 175 | 300 | 220 | 380 | 280 | 425 | 315 | 540 | 400 |
| 7/8 | 190 | 140 | 240 | 175 | 190 | 140 | 240 | 175 | 490 | 360 | 615 | 455 | 690 | 510 | 870 | 640 |
| 1 | 285 | 210 | 360 | 265 | 285 | 210 | 360 | 265 | 730 | 540 | 920 | 680 | 1030 | 760 | 1300 | 960 |
| 1-1/8 | 400 | 300 | 510 | 375 | 400 | 300 | 510 | 375 | 910 | 670 | 1150 | 850 | 1450 | 1075 | 1850 | 1350 |
| 1-1/4 | 570 | 420 | 725 | 535 | 570 | 420 | 725 | 535 | 1280 | 945 | 1630 | 1200 | 2050 | 1500 | 2600 | 1920 |
| 1-3/8 | 750 | 550 | 950 | 700 | 750 | 550 | 950 | 700 | 1700 | 1250 | 2140 | 1580 | 2700 | 2000 | 3400 | 2500 |
| 1-1/2 | 990 | 730 | 1250 | 930 | 990 | 730 | 1250 | 930 | 2250 | 1650 | 2850 | 2100 | 3600 | 2650 | 4550 | 3350 |

Torque values listed are for general use only, based on the strength of the bolt or screw. DO NOT use these values if a different torque value or tightening procedure is given for a specific application. For plastic insert or crimped steel type lock nuts, for stainless steel fasteners, or for nuts on U-bolts, see the tightening instructions for the specific application. Shear bolts are designed to fail under predetermined loads. Always replace shear bolts with identical grade. Replace fasteners with the same or higher grade. If higher grade fasteners are used, tighten these to the strength of the original. Make sure fastener threads are clean and that you properly start thread engagement. When possible, lubricate plain or zinc plated fasteners other than lock nuts, wheel bolts, or wheel nuts, unless different instructions are given for the specific application.

Grade 2 applies to hex cap screws (not hex bolts) up to 6 in (152 mm) long. Grade 1 applies to hex cap screws over 6 in (152 mm) long, and for all other types of bolts and screws of any length. “Lubricated” means coated with a lubricant such as engine oil, fasteners with phosphate and oil coatings, or 7/8 in. and larger fasteners with JDM F13C zinc flake coating. “Dry” means plain or zinc plated without any lubrication, or 1/4 to 3/4 in. fasteners with JDM F13B zinc flake coating.

Lubrication

Grease all zerks on the 1975 Toolbar using a high-quality, multi-purpose grease. Follow the recommended hourly service intervals illustrated here. Grease more frequently dependent upon the frequency of folding.

| Lubrication Service Intervals | | |
|---|-------------|------------------|
| | Total Zerks | Interval (Hours) |
| Hitch (See Figure 7-1 on page 7-3.) | 2 | 10 |
| Lift wheel/track (6 used) (See Figure 7-2 on page 7-3.) | 18 | 10 |
| Outer wing pivot pin (2 used) (See Figure 7-3 on page 7-4.) | 2 | 20 |
| Outer wing hinge pin (2 used) (See Figure 7-3 on page 7-4.) | 2 | 50 |
| Outer wing fold linkage (2 used) (See Figure 7-3 on page 7-4.) | 8 | 20 |
| Midwing pivot pin (2 used) (See Figure 7-4 on page 7-4.) | 2 | 20 |
| Midwing strut pin (2 used) (See Figure 7-4 on page 7-4.) | 2 | 20 |
| Swing truss pivot pin (2 used) (See Figure 7-5 on page 7-4.) | 2 | 20 |
| Gullwing linkage (2 used) (See Figure 7-5 on page 7-4.) | 4 | 20 |

Hitch Grease Locations

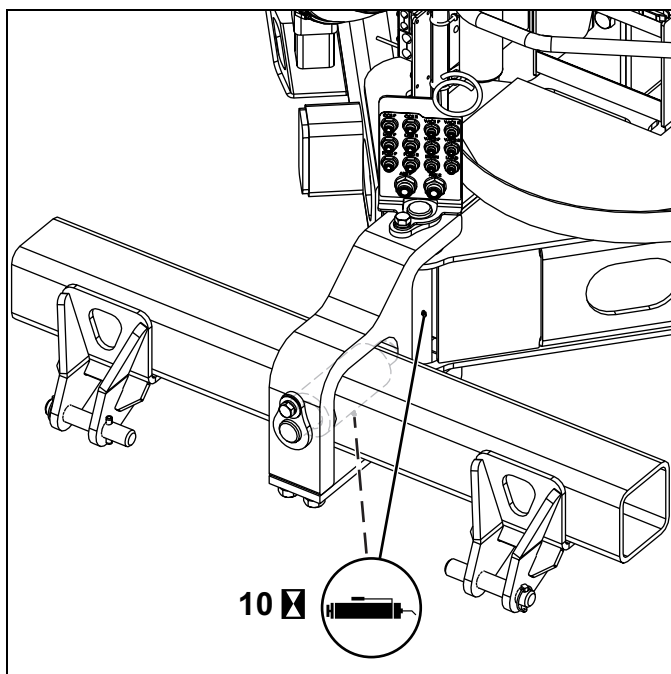

Figure 7-1

ORM000037

Lift Wheel/Track Grease Locations

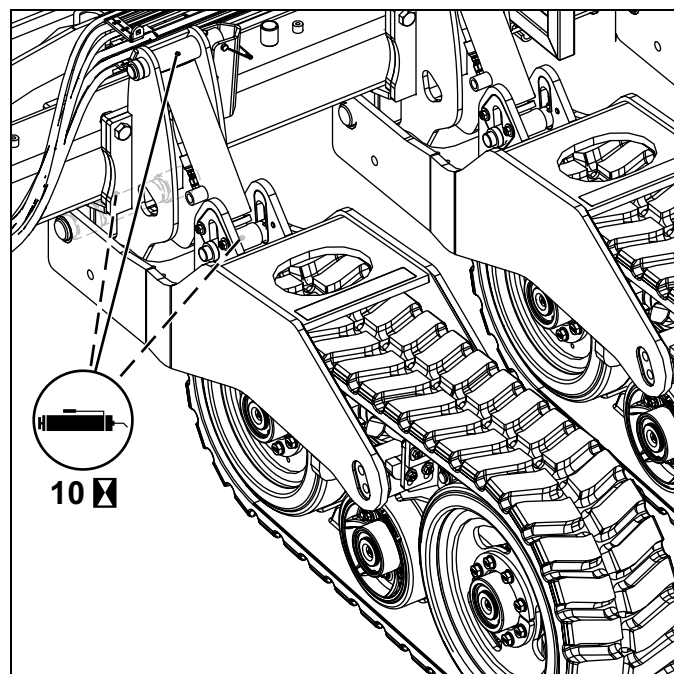

Figure 7-2

ORM000039

Outer Wing Grease Locations

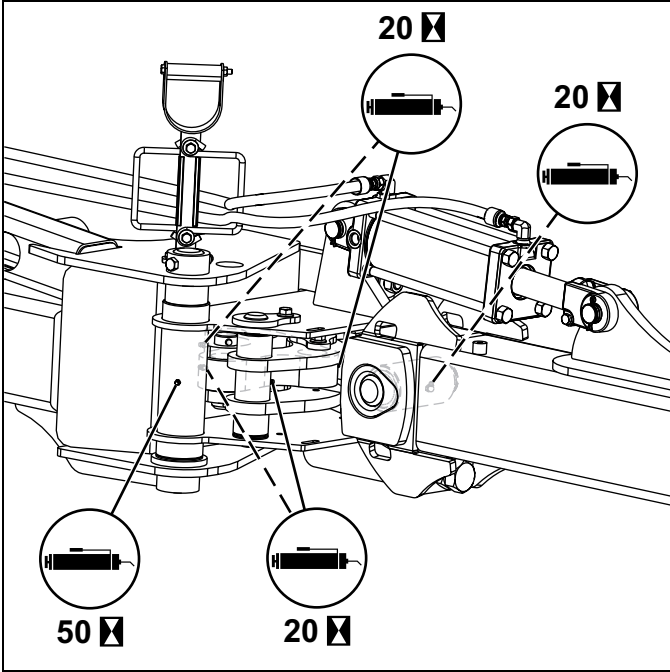

Figure 7-3: Left Outer Wing

ORM000040

Center Grease Locations

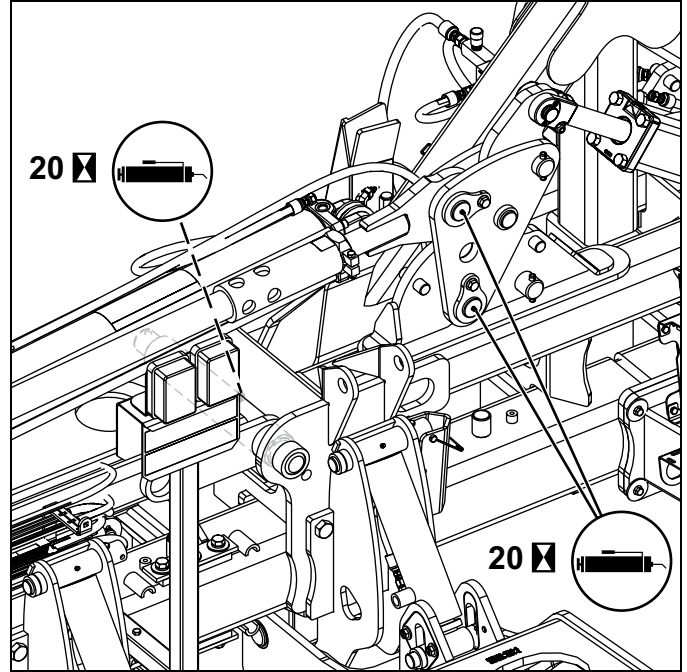

Figure 7-5: Left Gullwing

ORM000042

Midwing Grease Locations

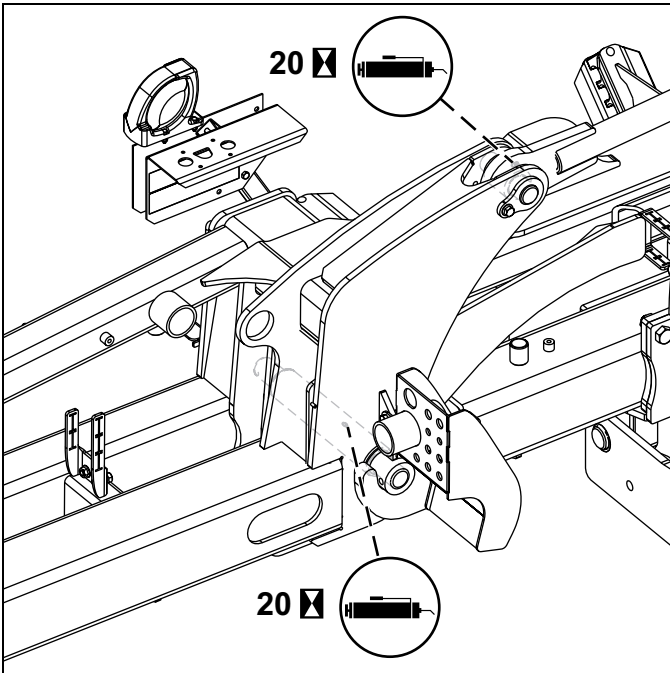

Figure 7-4: Left Midwing

ORM000041

Implement Inspection

Before each use, inspect implement for damaged or broken parts. Replace broken or worn parts immediately. When replacement parts are necessary for periodic maintenance and servicing, genuine factory replacement parts must be used in order to restore the implement to original specifications. Contact your Orthman dealer for replacement parts.

During break-in (40 hours), check hardware for proper torque every 10 to 20 hours. See “Torque Specifications” on page 7-2. Before each use, check hardware for wear and proper torque. Replace damaged or missing hardware with hardware of an identical grade to restore the implement to original specifications.

Remove any buildup of grease, oil, and debris.

Replace all shields and guards. Be sure all tools, parts, and service equipment are removed before you operate the implement.

Implement Storage

Prior to storing the implement for a long period of time, perform the following:

- Clean and touch up paint seasonally to avoid corrosion and rust. Contact your Orthman dealer for touch up paint.
- Inspect all safety decals and replace if missing or damaged. Contact your Orthman dealer for replacement decals. See “Safety Decals” on page 2-10.
- Grease all zerks regardless of hourly interval.
- Check all hardware according to torque specifications. See “Torque Specifications” on page 7-2.
- Inspect implement for damaged or broken parts. Replace parts as necessary.
- Remove any buildup of grease, oil, and debris.

Store inside if possible. Storing the implement inside will prolong the life of the 1975 Toolbar components.

DANGER

Avoid crushing. Failure to follow this information will result in death or serious injury. Use bar stands and cylinder stops to support the implement.

Store the implement on a clean, dry, level surface. An uneven surface could cause the implement to shift or fall, resulting in injury or death as well as implement damage. Securely support all implement components that must be raised. Store the implement away from human activity.

DANGER

Avoid crushing. Failure to follow this information will result in death or serious injury. Make sure all personnel are clear of the implement before lowering.

Lower the implement to the ground, place the tractor in park, turn off the engine, and remove the key.

Index

A

Anhydrous ammonia. See Liquid fertilizer

B

Bulkhead
Hydraulic connections 5-4

C

Center
Component identification 3-2

Central commodity system (CCS) planter tongue and hitch
Component identification 3-7

Component identification
Center 3-2
CSS planter tongue and hitch 3-7
Gullwing 5-2
Lift track 3-5
Lift wheel 3-4
Tongue and hitch 3-6
Wing 3-3

Counterbalance valve
Adjustment 4-12

D

Decals
Location 2-10,2-11

Delivery
Checklist 1-2
Pre-delivery checklist 1-2

Diagnostics. See Troubleshooting

F

Fold control manifold
Adjustments 4-12
Connections 4-10,4-11
Operation 4-10

Folding
Outer wing 4-5

G

Guidance system
Connection 4-14

Gullwing 4-7
Component identification 5-2
Down force 5-6
Features 5-2
Float 5-6
Hydraulics 5-3
Plumbing 4-7
Toolbar flex 5-5

H

Hydraulics
Bulkhead connections 5-4
Gullwing layout 5-3
Preventative measures 6-4
Troubleshooting 6-4

I

Implement. See Toolbar

L

Latch
Outer wing 4-6

Lift track
Component identification 3-5

Lift wheel
Component identification 3-4

Liquid fertilizer
Safety 2-9

Lubrication
Specifications 7-3

M

| | |
|--------------------------|-----|
| Maintenance | |
| Implement inspection | 7-5 |
| Implement storage | 7-5 |
| Lubrication | 7-3 |
| Notes | 7-6 |
| Safety | 7-2 |
| Torque specifications | 7-2 |
| Midwing | |
| Component identification | 3-3 |
| Leveling | 4-8 |

O

| | |
|--------------------------|-----|
| Outer wing | |
| Component identification | 3-3 |
| Fold | 4-5 |
| Latch | 4-6 |

P

| | |
|-------------------------------------|------|
| Preparation | |
| Adjusting the fold control manifold | 4-12 |
| Leveling the midwing | 4-8 |
| Toolbar | 4-2 |

S

| | |
|----------------------|---------|
| Safety | |
| Decals | 2-10 |
| Farm | 2-2 |
| Farm hazards | 2-3 |
| Liquid fertilizer | 2-9 |
| Maintenance | 2-8,7-2 |
| Operation | 2-5 |
| Shutdown and storage | 2-4 |
| Symbols | 2-4 |
| Transport | 2-5 |
| Warning lights | 2-6 |
| Sequence valve | |
| Adjustment | 4-13 |
| Serial number plate | |
| Description | 2-9 |
| Specification | |
| Lubrication | 7-3 |
| Torque | 7-2 |
| Storage | |
| Maintenance | 7-5 |

T

| | |
|--------------------------------------|------|
| Tongue and hitch | |
| CCS planter component identification | 3-7 |
| Component identification | 3-6 |
| Toolbar | |
| Connecting to tractor | 4-3 |
| Disconnecting from tractor | 4-4 |
| Field position | 5-8 |
| Flex | 5-5 |
| Guidance system | 4-14 |
| Gullwing down force | 5-6 |
| Gullwing up | 5-6 |
| Inspection | 7-5 |
| Orientation | 5-7 |
| Preparation | 4-2 |
| Preventative measures | 6-2 |
| Raised position | 5-7 |
| Storage | 7-5 |
| Troubleshooting | 6-2 |
| Torque | |
| Specifications | 7-2 |
| Troubleshooting | |
| Hydraulics | 6-4 |
| Toolbar | 6-2 |

W

| | |
|--------------------------------------|-----|
| Warranty | 1-4 |
| Wing. See Midwing, or see Outer wing | |

Intentionally Left Blank Page

ORTHMAN MFG

75765 Road 435

Lexington, NE 68850

USA Ag Products: 308-324-4654

USA Repair Parts: 866-324-7519

South Africa Ag Products: (+27) 12-940-2155

For repair parts or service contact your certified Orthman dealer.

Orthman.com

